

Wireless World

Radio • Electronics • Electro-Acoustics

34th YEAR OF PUBLICATION

JULY 1944

Proprietors :
ILIFFE & SONS LTD.

Managing Editor :
HUGH S. POCKOCK,
M.I.E.E.

Editor :
H. F. SMITH.

Editorial, Advertising
and Publishing Offices:

DORSET HOUSE,
STAMFORD STREET,
LONDON, S.E.1.

Telephone :
Waterloo 3333 (35 lines).

Telegrams :
"Ethaworld, Sedist, London."



PUBLISHED
MONTHLY

Price : 1/6

(Publication date 25th
of preceding month)

Subscription Rate :
Home and Abroad
20/- per annum.

MONTHLY COMMENTARY	193
PRINCIPLES, THEORY—AND PRACTICE.. ..	194
R-F PENTODES AS A-F AMPLIFIERS.	
By S. W. Amos, B.Sc. (Hons.), Grad.I.E.E. . . .	196
ÆSTHETICS OF SOUND REPRODUCTION	
By H. A. Hartley	198
AUTOMATIC RADIO RELAYING	
By D. A. Bell, M.A.	203
RANDOM RADIATIONS. By "Diallist"	204
NON-INTERFERING A-C MOTORS.	
By N. F. T. Saunders, B.Sc., M.I.E.E. . . .	206
RADIO DATA CHARTS—16.	
Voltage Gain of Resistance-Coupled Amplifiers.	
By J. McG. Sowerby, B.A., Grad.I.E.E. . . .	209
RADIO HEATING EQUIPMENT—IV.	
By L. L. Langton, A.M.I.E.E.	212
NEXT SUNSPOT CYCLE	214
WORLD OF WIRELESS	216
R.M.A. REPORT	219
UNBIASED. By Free Grid	220
LETTERS TO THE EDITOR.. .. .	221
RECENT INVENTIONS	224

Branch Offices :

COVENTRY :
8-10, Corporation Street.
Telephone : Coventry 5210.
Telegrams :
"Autocar, Coventry."

BIRMINGHAM :
Guildhall Buildings,
Navigation Street, 2.
Telephone :
Midland 2971 (5 lines).
Telegrams :
"Autopress, Birmingham."

MANCHESTER :
260, Deansgate, 3.
Telephone :
Blackfriars 4412 (4 lines).
Telegrams :
"Iliffe, Manchester."

GLASGOW :
26B, Renfield Street, C.2.
Telephone : Central 4857.
Telegrams : "Iliffe, Glasgow."



As many of the circuits and apparatus described in these pages are covered by patents, readers are advised, before making use of them, to satisfy themselves that they would not be infringing patents.

Miniature I.F. Transformers

DESIGNED FOR MAXIMUM
GAIN AND SELECTIVITY IN
THE SMALLEST DIMENSIONS

The coils are contained in enclosed pot-type iron dust cores, tuning adjustments being obtained by means of adjustable iron dust centre cores.

Fixed tuning condensers are contained inside the screening can.

The following frequencies are preferred standards but others are available for particular applications :—

M.400 - - 460 Kc/s. M.405 - - 1.6 Mc/s.
M.411 - - 2.1 Mc/s. M.415 - - 4.86 Mc/s.
M.418 - - 9.72 Mc/s.

Wartime restrictions prevent our accepting orders other than those covered by priority numbers.

The illustration shows the actual size of the Unit which is provided with one hole fixing, the terminal wires being fed through insulated bushings which, in turn, prevent movement of the transformer when mounted in position.

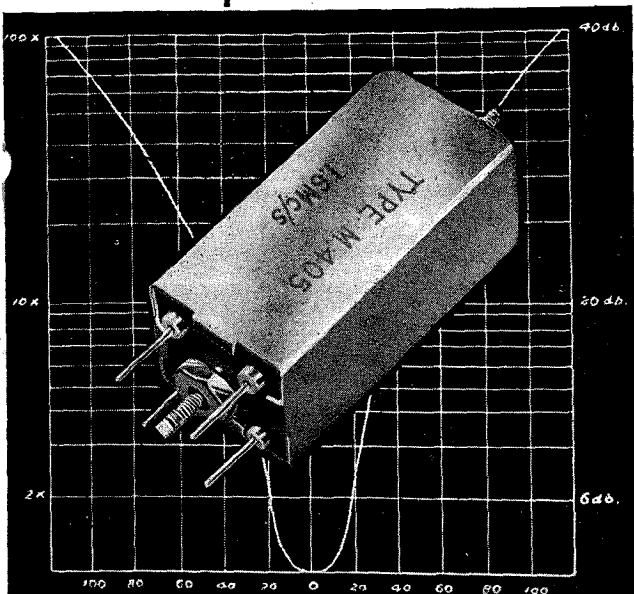

WRIGHT & WEAIRE LTD.
HIGH ROAD, TOTTENHAM, N.

Telephone : TOTtenham 3847-8-9.



X-Rays

There are no fanfares for him; no news-reels show him in action; he wields no weapons more lethal than a slide-rule. But he is instrumental in placing a great invisible power in the hands of others.

He—and his colleagues of the research and development laboratories—have made it possible to see deep into the heart of the metal of vital things like aero engines and gun barrels, to make sure that no hidden flaws exist; they have

given to doctors and surgeons an ally of ever-increasing power and scope for diagnosis and cure; to them belongs much of the credit for the part which mass radiography will play in the final elimination of the scourge of tuberculosis.

He and his colleagues have contributed greatly to Philips leadership in the field of X-rays. Their knowledge and experience are of vital importance to the nation today.

PHILIPS



RADIO ★ LAMPS

AND ALLIED ELECTRICAL PRODUCTS

PHILIPS LAMPS LTD., CENTURY HOUSE, SHAFTESBURY AVENUE, W.C.2 (28D)

Wireless World

Radio • Electronics • Electro-Acoustics

Vol. L. No. 7

JULY 1944

Price 1s. 6d.

Monthly Commentary

Governing Principles of Frequency Allocation

IT is generally agreed that one of the most pressing needs in the world of wireless is a new international agreement on the allocation of frequency bands between the various services. Obviously that need cannot be fully met until after the war, but we have already suggested that the urgency of the matter justifies an attempt to bring about an interim agreement before the end of the war. If a conference could be arranged, the work of the delegates would be simplified and expedited if a few clearly stated principles for their guidance could be agreed beforehand.

A recent Chatham House publication, "International Telecommunications"* discusses the international organisation of communication services, and although its suggestions relate mainly to the post-war period, much consideration is given to general principles. Some publicity has been given to a statement in the book that at the Madrid International Convention of 1932 the proposal was made that in any wavelength allocation priority should be given to services that cannot use other means of communication. Though that proposal was not looked upon with favour either at Madrid or at the Cairo Convention in 1938, there now seems to be a danger that it may be accepted and given a much wider interpretation than was intended when the idea was first put forward. The opinion is now often expressed—sometimes in circles that are not quite disinterested—that wireless should be restricted entirely to services where one or both of the stations concerned are mobile; in other words, to cases where a metallic link is physically impossible.

Now *Wireless World* cannot claim to be disinterested, but it costs us no great effort to admit that at some time in the indefinite future wireless may well be entirely restricted to those uses for which the wire will not serve. But that time is not yet; the literal application of the principle would certainly hinder human progress. For

example, there is no physical or technical reason why internal broadcasting should not be distributed universally by wire. But apart from other considerations, it would at present be economically impossible to do so in most countries. A similar argument applies to television, of which the practical development would be postponed indefinitely if it were decided that it should be distributed to the viewer by cable. Taking the most tolerant view, the principle under discussion cannot yet be accepted without reservations. At the most, it may be regarded as an ideal for the future.

A second principle proposed at Madrid and mentioned in "International Telecommunications," is less controversial: between competing services, "priority should be given to the one which has the greatest social importance." That seems to offer safe guidance to those whose task it will be to organise the future use of wireless.

Controlling All Radiation.—Agitation in favour of legislation against avoidable interference with wireless reception is carried a stage farther by a suggestion put forward by the British Institution of Radio Engineers. It is made in a Report from which extracts are given elsewhere in this issue, and is to the effect that there should be Government control of all electro-magnetic radiation. Medical and industrial uses of RF energy are cited, and it is suggested that control should no longer be confined to the transmission of intelligence.

Although we would deprecate the passing of any hasty legislation that might restrict the development of these important offshoots of radio technique, it seems inevitable that they should eventually be controlled. Except for temporary war-time restrictions, there is nothing to prevent the user of radio heating apparatus from radiating kilowatts of energy on any frequency he chooses.

Another new development—Radar—also has obvious interference-producing capabilities. It is interesting to speculate whether it can similarly be considered beyond the scope of existing legislation.

* By Brig. Gen. Sir Osborne Mance (Oxford University Press, 7s. 6d.)

PRINCIPLES, THEORY—AND PRACTICE

Early Ideas on Wave Propagation

THE most outstanding achievements in the early days of wireless telegraphy were accomplished in spite of principles and theory.

It is only fifty-five years since Hertz wrote, on December 3rd, 1889, in reply to an enquiry from a Herr Huber, that there was no prospect of his discovery being used for telephony, as the wavelength would be about 300 kilometres. "If," he said, "you could construct a mirror as large as a continent you might succeed with such experiments."

I might add here as a kind of footnote that although in his "Pioneers of Electrical Communications" the late Rollo Appleyard gives a translation of the letter from Hertz to Huber, he mistranslates "telephon" as "telegraph," due undoubtedly to his difficulty with Hertz's handwriting. Telegraphy is not mentioned in the letter.

Hertz died on January 1st, 1894; that is, fifty years ago, without knowing that he had laid the foundations of a new and revolutionary branch of electric communications, although Crooks had written in 1892: "Here is revealed the bewildering possibility of telegraphy without wires, posts, cables, or any of our present costly appliances . . . and by concerted signals messages in the morse code can thus pass from one operator to another."

Many of the most outstanding advances in wireless telegraphy have been made, not along lines indicated by a

study of principles and theory, but rather contrary to such indications, and the success achieved has then led to a revision of the principles and theory.

It is nearly 40 years since Pro-

The following is the text of an address delivered by Prof. G. W. O. Howe, D.Sc., M.I.E.E. (Technical Editor of our associated journal *Wireless Engineer*), at the recent Commemoration Meeting of the Wireless Section of the Institution of Electrical Engineers

fessor Ayrton told me, with a slightly malicious twinkle in his eye, that the reason that Marconi and not Lodge was the first to transmit radio signals across the English Channel was that Lodge was so well versed in electromagnetic theory that he knew it was impossible, whereas Marconi, not knowing that it was impossible, went and did it.

If in 1900 Marconi had consulted a panel of the leading scientists as to the feasibility of sending wireless signals across the Atlantic it is doubtful whether he would have made his classic experiment. They would have pointed out to him that the electromagnetic waves employed were of the same nature as light, and that between Cornwall and Newfoundland there was a mountain of sea water over a hundred miles high. Principles and theory

menched by Heaviside and Kennelly in 1902 and which has been pursued ever since by a number of scientists with wonderful results.

So improbable did trans-Atlantic telegraphy appear that there was much scepticism among scientific people when it was first announced that Marconi had received the signals in Newfoundland.

In the 'eighties Balfour Stewart had suggested the existence of a conducting layer in the upper atmosphere as a cause of fluctuations in terrestrial magnetism, but until the discovery of the electron and ionisation such a suggestion could be little more than a vague idea.

It is very interesting now to read the section dealing with this subject in Fleming's "Elementary Manual of Radio Telegraphy and Telephony," published in 1908, that is, 36 years ago. Ionisation of the atmosphere is mentioned, but only to explain the absorption of the waves and the variation of this absorption during the twenty-four hours. This ionisation, said Fleming, "cannot be wholly accounted for by radio activity of the sea and soil. Knowing, however, that ultra-violet light is the cause of ionisation and [that]

perhaps the penetration of the upper layers of the atmosphere by cosmic matter carrying electric charges is another possible cause, we may no doubt assign to these agencies some share at least in the production of a atmospheric ionisation. . . .

Air exposed to sunshine, although it may be extremely transparent to light waves, acts as if it were a slightly turbid medium for long electric waves." Fleming put this explanation forward as an alternative to

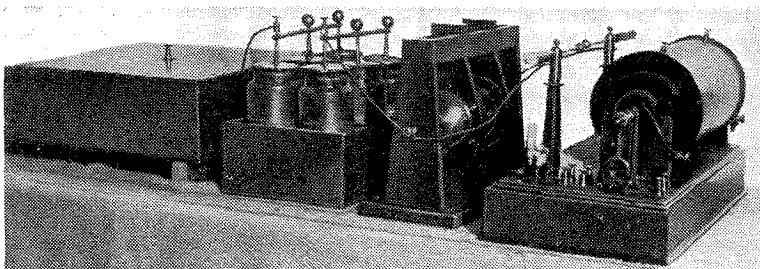

It was with gear like this that the outstanding achievements of the early days of wireless telegraphy were accomplished "in spite of principles and theory". This Marconi transmitter, exhibited at the I.E.E. Wireless Section Commemoration Meeting, comprises (right to left) induction coil, spark gap, Leyden jar battery and "jigger" (aerial coupling transformer)

were all against him, but fortunately he made the experiment and gave those versed in the principles and theory the task of adjusting them to explain the facts, a task which was com-

Marconi's suggestion that the variations were due to the dissipative effect of sunlight falling upon the transmitting aerial.

In explanation of the mystery of the transmission of the waves around an eighth of the earth's circumference, Fleming says: "It has been suggested that the conductivity of the upper layers of our atmosphere is sufficiently great to confine the waves to a spherical shell of the lower atmosphere, but no data at present available give support to the conclusion. We have already indicated that the possible cause of this advantageous transmission round the terrestrial sphere is due to the earth connection of the transmitting and receiving antennæ, whereby both these antennæ and the earth are practically converted into a single oscillator."

We see, therefore, that in 1908 the Heaviside layer was just mentioned as having been suggested but not taken very seriously.

Ten years elapsed after Heaviside's suggestion before any appreciable progress was made.

Mechanism of Refraction

I think that the first clue as to the real nature of the mechanism by which the electromagnetic waves are refracted was given by Dr. Eccles in 1912 and 1913. He said: "The hypothesis introduced by the author is based on the assumption that the sun's rays ionise the atmosphere in such a way that the concentration of ions increases gradually as we ascend in the atmosphere. In this event a ray started horizontally will pursue a curved path with its concavity towards the earth, and thus, if the ionisation is great enough, an electric ray may follow and overtake the curvature of the earth."

In his calculations Dr. Eccles assumed that the decrease of apparent permittivity was due to the movements of ions of molecular size, and it was a sign of the times that the wavelength assumed in his example was 5.4 kilometres.

The war then intervened and little more progress seems to have been made in the principles and theory of the ionosphere until 1924, when Larmor contributed a paper to the *Philosophical Magazine* entitled "Why Wire-

less Electric Rays Can Bend round the Earth." He stated that "the theory was hammered out in class lectures at Cambridge on electric waves, and had been already expounded in answers in the *Mathematical Tripos*." It was an extension and development of Eccles' theory but taking the electron and not the molecular ion as the operative agent in the reduction of permittivity. Things now began to move more rapidly. Although in September 1925 Smith-Rose and Barfield, in connection with their direction-finding researches, were of the opinion that "adequate experimental evidence of the existence of the Heaviside layer is still lacking," in the following month Appleton and Barnett showed from an experimental examination of the phenomenon of fading that it was due to waves deviated through large angles by the upper atmosphere, and that the waves were elliptically polarised in accordance with the magneto-ionic theory, and that there must be at least 100,000 electrons per cubic centimetre in the ionised layer. In the following year Appleton and Barnett showed by experiments in which the wavelength was rapidly changed and the interference fringes photographed, that the height of the layer increased during the night and decreased rapidly about sunrise.

Notwithstanding this, in the following year (1927) Banneitz in his "Taschenbuch der Drahtlosen Telegraphie" says, after describing what he calls the Eccles hypothesis, "It is very probable that these theories will one day be replaced by others that will prove more suitable for explaining the transmission phenomena."

Thus 17 years ago some doubted the existence of the ionosphere, while others were exploring it and even determining the density of its population. In the same year we find Prof. P. O. Pedersen in his book "Propagation of Radio Waves," p. 70, accepting the ionosphere but saying with regard to the idea that it should normally be divided into several independent layers, an opinion which he says seems to be very widespread. "We cannot see any reason for assuming such a separation to exist. The features in connection with the propagation of radio waves may be explained in

a fully satisfactory manner on the basis of the ionisation of one single coherent portion of the atmosphere."

It is not for me, however, to throw any stones at Pedersen or Banneitz, for in September 1931 the Editorial in *Wireless Engineer* was entitled "How Many Ionised Layers?" It was based on a description of experiments made in Germany by Zenneck from which he concluded that the effects which suggested a second ionised layer were really due to waves reflected from the earth, which had done a second journey to the ionosphere and back. His experiments were all made, however, at a wavelength of 533 metres and the intervals which elapsed between successive signals always corresponded within the errors of observation to successive reflections from a single ionised layer. The Editorial pointed out, however, that great caution should be exercised in comparing results obtained at other wavelengths.

Proof at Last

This was after Sir Edward Appleton had christened the two layers E and F, but it shows that some doubt was still felt as to their existence. One had a feeling that it was an easy way out of a difficulty in interpreting results to invent a new Heaviside layer, but the powerful experimental method first devised by Breit and Tuve and used with such brilliant results by Sir Edward Appleton, and a number of workers guided and inspired by him, has put the matter beyond any doubt. To realise the complexity of the problem, one has to remember that the echo signal may have been turned back by either the E, F₁, or F₂ layer after doing the return journey once, twice or even three times, and that, owing to the earth's magnetic field, each signal sent out is divided into two with different ionospheric properties, but fortunately with different polarisations by which they can be identified. The conditions differ with the wavelength and with the time of day.

The knowledge that we now have of the constitution and properties of the ionosphere represents a triumph of combined operations between experimental research and principles and theory.

R-F PENTODES AS A-F AMPLIFIERS

Advantages over Triodes in Early Stages

IT has become customary in recent years, particularly in the design of P.A. amplifiers, to use resistance-capacity coupled RF pentodes of the "straight" or non-variable- μ type as voltage amplifiers, their chief advantage over triodes being that a much higher stage gain is possible. The SP41, for instance, can under suitable conditions give a stage gain as high as 400 times, which is many times greater than the highest value obtainable with a

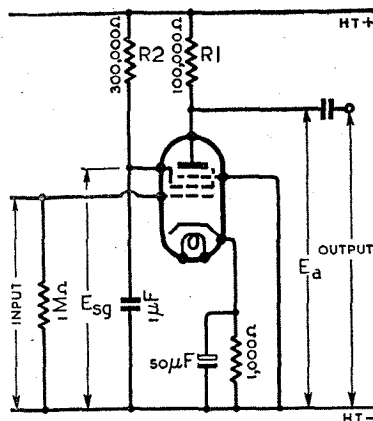

Fig. 1. Basic circuit for R-C coupled RF pentode as an AF amplifier.

triode. From the usual expression stage gain = $\mu R / R + R_a$ in which μ = amplification factor of the valve, R = value of anode resistance, and R_a = anode AC impedance of the valve, it is obvious that the greatest possible value for the stage gain is μ , this occurring for an infinite value of anode resistance. As μ for small triodes seldom exceeds 50, this value is the upper limit to the stage gain possible with such valves, but μ for RF pentodes can be as much as 8,000. Alternatively it is possible, using negative feedback, to reduce the stage gain of an RF pentode to the value obtainable using a triode, and by so doing the distortion introduced by the pentode will be many times less than that introduced by the triode.

It is the purpose of this article to discuss a number of important points to which attention should be paid in the design of AF

By S. W. AMOS,
B.Sc. (Hons.), Grad.I.E.E., A.M. Brit. I.R.E.

amplifiers using RF pentodes. As such pentodes have a very high value of R_a (its value is seldom less than 1 megohm) they behave, with normal values of anode load, as constant current generators, and should therefore only be used with purely resistive anode loads, if a response independent of frequency is wanted. If they are used with choke-capacitance or transformer coupling there will be a "top lift" in the reproduction due to the rise in the reactance of the anode load which occurs with increase in frequency. This can only be avoided if reactive loads must be used, by using enormous inductances of prohibitive size and cost, or by shunting normal components with resistances of about 30,000 ohms in value, but with the latter method the advantage of the high μ is entirely lost.

The basic circuit for an R-C coupled RF pentode is given in Fig. 1, and the first thing to note is that the screen potential, E_{sg} , should not exceed the quiescent value of the anode potential, E_a (i.e., the value of E_a with no

valve becomes inoperative. The same observation applies to the operation of output pentodes, of course, but for these the quiescent value of E_a is obvious, being only a few volts less than the HT supply voltage (the voltage drop across the primary winding of the average output transformer is very small). In Fig. 1 the quiescent value of E_a is not obvious as the load resistance R_1 may have any value up to 100,000 ohms, but we can calculate the correct value for R_2 quite easily as follows. In the majority of RF pentodes the screen current is usually equal to a definite fraction of the anode current over quite a wide range of operating conditions. The value of this fraction can be ascertained from the literature supplied with each valve by the manufacturers. For the ACSP3 the fraction is approximately one-third, whereas it is roughly one quarter for the SP41. Let us suppose that the valve in Fig. 1 is an ACSP3. It is clear that if the screen potential is to equal the quiescent anode potential, a good working arrangement, then R_2 must be three times the value of R_1 so that the voltage drop across R_2 equals that across R_1 . R_2 should therefore be 300,000 ohms if R_1 is 100,000

ohms. This rule will not apply if the screen is fed from a potential divider across the HT supply.

Many quality enthusiasts look askance at pentodes used as audio-frequency amplifiers, being somewhat nervous about the

amount of harmonic distortion they introduce, and it is certainly true that they cause some third harmonic in addition to second harmonic distortion. Second harmonic distortion occurs when the positive and negative peaks of a sinusoidal input signal are amplified unequally giving a "flattening" effect on one peak. The E_a - I_a curves of a pentode show the opposite form of curvature from

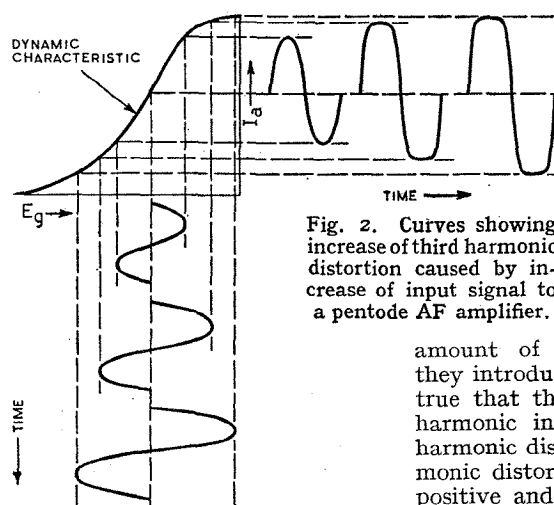

Fig. 2. Curves showing increase of third harmonic distortion caused by increase of input signal to a pentode AF amplifier.

signal on the grid) by more than about 20 volts, otherwise the screen tends to monopolise all the emission from the cathode and the

the E_g-I_a curves, so that second harmonic distortion tends to cancel, and for one particular value of anode load for each set of operating conditions it is true that second harmonic distortion cancels completely. Unfortunately the same cannot be said of the third harmonic distortion so that this form is as inevitable with pentodes as second harmonic is with triodes. This is illustrated

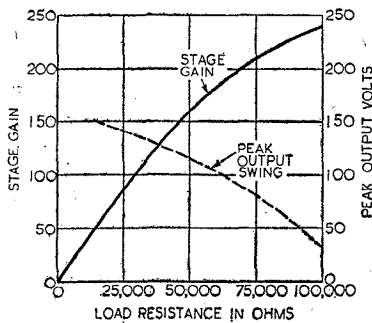

Fig. 3. Relationship between stage gain output volts and load resistance for 2 per cent. third harmonic distortion, in a high-slope pentode with 250 volts HT supply.

by the nature of the dynamic E_g-I_a characteristic for a pentode valve which is given in Fig. 2. This diagram shows how the amount of third harmonic distortion measured by the amount of flattening of both peaks increases with the extent of the grid—and hence the anode—potential swing. To keep this form of distortion at a low level, therefore, the anode potential swing should be limited and, in particular, it should not swing in the negative direction so that it approaches zero. As high values of anode load lower the quiescent value of E_a , for a given percentage of third harmonic distortion the swing of anode potential becomes progressively less as the value of the anode load is increased. One should not therefore attempt to get a great voltage output from a pentode with a very high value of anode load, and a good rule is to use the lowest value of anode load which will give the desired output. Clearly, too, a high value of HT voltage is desirable, for the greater this is, the higher will be the quiescent value of E_a and so the smaller the percentage of third harmonic distortion introduced. All these points are brought out in Fig. 3, which shows how the output obtainable for

2 per cent. third harmonic distortion and the stage gain of a "television" type RF pentode vary with the value of the load resistance. For every point taken the screen potential was adjusted to equal the quiescent value of the anode potential.

One difference between directly and indirectly heated valves is that the latter, by virtue of their equipotential cathodes, start to take grid current even when the grid is appreciably negative with respect to the cathode. This effect is particularly noticeable in the case of high-slope RF pentodes which in some cases begin to take grid current when the grid is as much as three-quarters of a volt negative with respect to the cathode. One should therefore take care to see that adequate grid bias is used to prevent grid current flowing during any fraction of the input cycle. In practice a grid bias resistor of 1,000 ohms is usually suitable for the high-slope type of valve.

Even if a large value of stage gain is not required it is still worth while using an RF pentode instead of a triode for AF amplification, for negative feedback can be used to reduce the stage gain of the pentode to the required value, and it will also, of course, reduce the amount of distortion introduced in the ratio in which the gain is reduced. Suppose, for example, that a stage gain of 40 times is wanted. A pentode could do this with ease: a triode could do it if worked "flat out" and the fact that it is "flat out" means that the distortion content will be fairly high. Using a valve of the SP41 type with a load resistance of 70,000 ohms and the appropriate screen potential we shall probably get a stage gain of some 200 times, as shown in Fig. 3. By using the correct degree of negative feedback this can be reduced to the required value of 40 times. The amplification, M' , given by a valve with feedback is given by $M' = M/(1 + a \cdot M)$ in which M is the amplification without feedback and a is the fraction of the output voltage which is fed back to the grid circuit. This expression can be put into the form $a = (M - M')/MM'$ which is useful for showing the degree of feedback required to produce a desired value of stage gain, M' . Substituting the values appropriate

to the example quoted, namely $M = 200$ and $M' = 40$ we have $a = 1/50$. This value of feedback, then, will reduce the voltage gain by five times, to the wanted value. It will do the same with the distortion content, and if we had 2 per cent. total distortion before, we shall only have 0.4 per cent. after the application of feedback. In these circumstances the performance of a pentode valve is vastly superior to any triode.

One way in which voltage feedback could be applied is shown in Fig. 4. Attention should be paid to the following points in order to secure the desired performance. R_1 and R_2 should be chosen so that $a = R_2/(R_1 + R_2)$ in order that the right value of feedback is used. R_1 should greatly exceed R_3 to avoid shunting and therefore effective reduction in the value of the anode load. The reactance of C should be very much less than R_1 at the lowest frequency wanted. The values indicated in Fig. 4 satisfy these conditions fairly well. Incidentally the conditions governing the choice of values for C and R_1 are precisely those quoted for the choice of an AF coupling con-

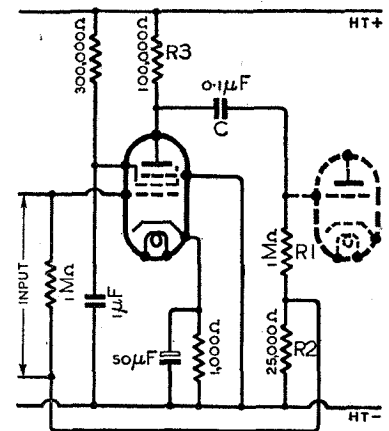

Fig. 4. One method of applying voltage feedback to a pentode AF amplifier.

denser and succeeding grid leak, and therefore there is no reason at all why C and R_1 should not be the coupling condenser and grid leak of the following valve, as suggested by the dotted lines in Fig. 4. The adoption of this scheme will avoid further reduction of the effective value of R_3 which would be caused by the addition of a second coupling

AESTHETICS OF SOUND REPRODUCTION

High Fidelity or Judicious Distortion?

By H. A. HARTLEY

THE object of this essay is to try to show that that particular branch of electronic gymnastics usually known as "high-fidelity reproduction" has not, by itself, got the value to a trained musician or music lover it is supposed to have, since it falls between the two stools of attempted but unsuccessful imitation on the one hand and spontaneous creative art on the other.

I am fully aware that, in putting forward such a point of view, I am attempting to knock away the foundations of a platform on which I have stood for more years than I care to think of; but I also feel sure that with riper experience one should change one's mind if one feels called on to do so. So I have changed my mind. I am no longer an exponent of plain, unadulterated high-fidelity reproduction. I shall give the reasons why I have changed my mind, and also what technical steps I have taken to achieve what I consider musically satisfying electronically synthesised sound.

The latter phrase is used quite deliberately. A high-fidelity gramophone or radio set does *not* give a high-fidelity reproduction of a musical composition as performed by an orchestra. The "reproduction" is much lower fidelity than a four-colour process reproduction of an oil-painting. It is *not* a reproduction at all. What it *is* shall be deferred for the moment, but I call it electronically synthesised sound, and as the mechanical properties of the loudspeaker have also something to say in the matter, we might shorten the phrase and say just "synthetic sound." The pedants will say, of course, that nearly all sounds are synthetic, but the reader will know what I mean.

What is "High Fidelity"?—I wrote an article in 1932 called "Broadcast Reproduction" (*Wireless World*, May 4th and 11th, 1932, pp. 442 and 487). In

it I showed that, for reasonably realistic reproduction of speech and music, the frequency response curve of the whole system should be a level straight line between the limits of 32 and 9,000 cycles per second. The classic experiments of the Bell Telephone Laboratories indicated that the upper limit should be 11,000 cycles per second, and recently Dr. F. G. Dutton ("Recording and Reproduction of Sound," I.E.E., Feb. 15th, 1944) showed that the frequency response range might well go as high as 12,000 c/s.

It must be remembered that in the far-off days of 1932 there were two schools of thought bitterly opposed to each other. The one said that the frequency band from 5,000 to 10,000 cycles succeeded in reproducing only interference, noise and scratch, and contributed nothing to the musical quality; the other said that any listener with the slightest pretensions to having a musical ear would at once perceive that a cut-off at 5,000 cycles ruined the reproduction of most musical instruments, all "programme noises" and the human voice. Time proved the "mellow cello" school wrong, but a new controversy arose. Was it better to cut at 5,000 and eliminate scratch and interference, or was it preferable to put up with a noisy background for the sake of good musical quality? There has never been a settlement of this argument, and there never can be, for personal preference enters so completely into the points of view of protagonists in such an argument that it is not amenable to reasoned discussion. "I like what I like" stands completely unassailable.

Musical Taste and Understanding.—This business of personal preference is usually known as "taste," and, judged by certain

accepted artistic standards, a person may be said to have good taste or bad taste. But it is not all so simple as that. For example, Mr. Eric Coate's "Calling All Workers" is much liked by a very large number of people, but ignored by musicians and music lovers of refined and educated discrimination. This is no slight on Mr. Coates, who professedly writes, and does it very well indeed, what is usually called "light music." But, by the accepted canons of art, a person who likes "Calling All Workers" and dislikes Beethoven's Seventh Symphony is a person of bad musical taste.

Going, now, a stage further, what are you going to say about a person who likes Tchaikovsky's First Piano Concerto, but doesn't like Bliss's Piano Concerto? I think the musical connoisseur would say that anyone who likes the Tchaikovsky Concerto is damned beyond hope, but I think he is much more advanced on the road to good musical appreciation than the person who adores the Warsaw Concerto. There are subtle things in musical composition which finally determine whether a certain work is great or merely superficially attractive. The Warsaw Concerto is pseudo-classical; the Tchaikovsky is not great but it has its points; the Brahms No. 2 Concerto is a great work. Now it is coming to pass that the Bliss Concerto is being regarded as a great work, so what can we say about the man who says he likes the Brahms but not the Bliss, and likes the Beethoven Seventh Symphony but not the Bax Third Symphony? It is not a question of taste now, for we are dealing only with musical compositions of undoubted merit. What our friend really means is this: that he understands and appreciates the Beethoven Symphony, but does not understand, and so cannot appreciate, the Bax Symphony.

I hope the reader will now

appreciate that I am trying to show the difference between musical taste and musical understanding, for it has a great bearing on "reproduction" of music. Taste divorced from understanding will determine whether you cut off at 5,000 or 10,000 cycles, but what does understanding determine?

Responsibilities of the Scientist.

—Scientists have recently had an opportunity of trying to thrash this out with a very distinguished musician. Dr. Malcolm Sargent has given his views on "High Fidelity Reproduction" (Brit. I.R.E., March 9th, 1944), and we are at once brought into the realms of art. The scientist may properly object that he has nothing to do with art when he is acting as a scientist, and will probably add that the artist, qua artist, cannot presume to interfere with science. This, unfortunately, must result in stagnation or even worse. All around us we see the result of the scientist allowing his science to be used for purposes he never envisaged when he made his discoveries. I maintain that the scientist should also take an interest in art, for without a social and artistic aim, science becomes abortive. The politician and the artist may ask for something which is scientifically impossible, but if the politician, the artist, the citizen, and the scientist collaborate, something useful will emerge. What can emerge in the field of synthetic sound?

Reproduction is Not Artistic.—

Dr. Sargent says that what should not emerge is high-fidelity reproduction, in other words, imitation. He maintains, and I am convinced he is right, that imitation cannot be artistic. It will be difficult, at first thought, to appreciate that the nearer you get to *reproducing* an orchestra playing a certain composition, the further you are getting away from artistic presentation of that work in your own home. Let me illustrate what I mean by reference to reproductions of pictures. An artist in oils will paint a canvas and the result is a work of art. The artist has not only mastered the technique of handling his tools and materials, brushes, knife, pigments, but he has taken care that the composition of the picture is right, that the colours

are applied with artistic discretion, and that the way the paint has been put on the canvas is in sympathy with the subject matter of the composition. Now, by photo-mechanical processes, let us turn out a hundred reproductions of that oil-painting. Those copies are not works of art, they are but imitations of a work of art because the result is not what the artist intended. He designed his painting on the basis of oil pigments on canvas, and the printed reproduction is something totally different both as to materials and surface. On the other hand, an artist may engrave a copper plate, and inked impressions from that copper plate, etchings, are works of art because the artist intended that the technique he used should be the technique of taking inked impressions of his engraving on sheets of paper.

Now the scientist may say "I accept this analogy, and since I am in the position of the colour-printer, I must, like the colour-printer, make my method as faithful as his. I am not an artist, I am concerned only with imitating works of art, and the best I can do is to provide a good imitation." This is logically sound, but is open to objections. I have said that the scientist must be more than a scientist, and Dr. Sargent says that the musician is not interested in imitations. And since he is not interested in imitations, he is not called upon to answer the question which was put to him at the meeting I referred to, which asked "If perfect reproduction is not scientifically possible, what sort of distortion will the musician object to least?"

The question we have to ask ourselves is, "What sort of sound synthesis is artistically satisfying?" The answer I propose to give is, "Something other than high-fidelity reproduction." The chief difficulty with high-fidelity reproduction is that it is continually letting you down. You begin to get into the way of thinking that what you have got is pretty well the real thing, and before you know where you are you suddenly become conscience that there is something there which ought not to be there. Whether the intervening medium is a record, film or "the ether," there is a distorting medium which cannot be corrected. With a trained ear and

a wide frequency response, distortion of the upper harmonics becomes acutely noticeable, and the more scratch and interference is eliminated by good technique (not by cutting the top) the more noticeable this distortion becomes. It is difficult to see how this form of distortion can ever be overcome. Possibly the best results will be obtained from high-fidelity wired wireless, but what shall we do about our personal libraries on disc and film?

My own experiments have tended to prove that the keenest artistic enjoyment is to be secured when the response curve has been "doctored." I find that the doctoring has to be varied according to the nature of the thing one is listening to, and the doctoring has to be done with a fine sense of artistic discretion. Putting it briefly, I start off with a high-fidelity radiogram, and then, according to my mood and the mood of my fellow listeners, I do certain things to the electrical and acoustic properties of the apparatus, so that what issues from the loudspeaker is artistically satisfying. All this is perfectly legitimate. I did not design my radiogram merely to be able to show a fellow technician that I was capable of producing a technical marvel; I designed it so that I should get pleasure and satisfaction from listening to the music, the synthetic sound it made. The instrument and the control knobs were my brushes and pigments, and the room was my canvas. I have found, as have my friends, that there is far more emotional "kick" to be got from the result than I ever got from straight high-fidelity reproduction, so called.

Now this means that my musical taste as well as my musical understanding has been imposed on the sound; but in saying this I hope a misunderstanding will not arise. If, as a designer, I included a top cut-off at 5,000 cycles per second, then those who used instruments made to my design would have my taste interfering with their taste. If I provided a "high-fidelity" instrument without control knobs, then the individual listener could not gratify his desires. So I must provide a number of knobs which can alter the response curve in various ways, but the original

Aesthetics of Sound Reproduction—curve must be as wide and flat as possible. Thus the listener is able to gratify his taste and his musical understanding.

His taste is satisfied by his choice of broadcast programmes and records, and by his freedom to choose between "mellowness" and "high-fidelity." His understanding is satisfied in a more subtle way. What he is listening to is not the sound that was produced in the studio, nor may it be what the composer intended he should hear. It is something quite different, and different in colour or texture but not in form. Dr. Sargent pointed out that a great artist could take liberties with Beethoven; but if you are not a great artist then it is better to play straight Beethoven. A listener to reproduced music cannot interfere with the form of a Beethoven composition, but as its colour or texture has already been interfered with before it reaches the listener's room, further interference is justified if the final result is more acceptable to a discriminating ear. The nature of that further interference is determined by musical understanding of what was likely to have been in the composer's mind in the first place, and, in addition, understanding of what constitutes artistic knowledge and creation of a series of musical sounds, even if different from the original conception.

In parentheses, it might be pointed out that Dr. Sargent believed in the idea of composing music for reproduction by electrical methods, for entirely new effects could be achieved which were impossible in a concert hall. This does not imply the use of electronic musical instruments, but that individual instruments can be given a power not possible under purely acoustic conditions. With this sort of composition a knobless reproducer of predetermined specification is essential. The composer is using known materials to achieve a certain artistic result.

The Sorts of Distortion to be Avoided.—In a technical sense, this doctoring of the response curve means distorting the response curve, and where we are adding distortion to distortion already present (since anything less than

absolutely perfect reproduction must contain distortion) we must be careful not to introduce distortion which will offend a sensitive musical ear. Some of the things that must be avoided at all costs are cabinet resonances, air column resonances in the cabinet, noticeable resonances in the speaker and pick-up, valve overload, bass and treble attenuation. The resonant types of distortion are very distressing. Pseudo-bass from a cabinet or speaker becomes a one-note thump which accompanies all music. The customary 3,000-cycle resonance in a poorly designed speaker does not give brilliance to the reproduction but merely "edge," which becomes extremely fatiguing and does not allow one to "turn the wick up" when it is felt that this is necessary. Absence of real bass takes the body out of the music; absence of top deprives the musical instrument of its characteristic quality, and orchestral works become muddy, indeterminate noises lacking depth and clarity and any musical value. Valve overload gives rise to very unpleasant harmonic distortion, which, however acceptable it may be in a factory broadcasting system, is unbearable in a home musical performance for discriminating listeners.

It will have been noted that resonances, which mean excessive output at some particular frequency, are to be avoided; they must also be avoided for another reason. The surface noise, or scratch, from a gramophone record is reproduced with great intensity when there are well-marked resonances in the speaker or pick-up; it is almost innocuous when the overall response is flat, even when there is no top cut-off below, say, 10,000 cycles per second. It will be seen, therefore, that scratch is not to be eliminated by cutting top, for if the speaker resonance is at 3,000 cycles the cut would have to be below this, and the musical quality resulting from such a cut would be valueless. Scratch can only be subdued by having an overall response in which there is no output peak due to resonances.

The Sort of Distortion that is Needed.—So far, then, I have postulated that resonances must

not be present, that there must be neither bass nor treble cut, that there must be no harmonic distortion due to valve overload. This seems to be a specification for high-fidelity reproduction, and so it is. Where, then, does the "doctoring" come in? The answer is to put *depressions* in the response curve, their width and depth depending on the effects to be achieved. I have found, by comprehensive experimenting over a long period, particularly on records, that while the ear is acutely sensitive to peaks on the response curve it does not appear to notice the presence of valleys, or, at any rate, of canyons and gorges. If, however, these canyons and gorges can be introduced in certain variable ways, for the ways must be variable according to the effect desired, a good deal of the noticeable imperfections in musical reproduction can be taken out without in any way spoiling the musical quality of the instruments. Quite obviously a response curve with canyons must introduce amplitude distortion which does not exist in a flat response, but the result is more artistic, and lines up with Dr. Sargent's contentions that truth is not necessarily beauty, that high-fidelity is to be avoided if you want to be artistic, that beauty begins where utility ends.

Practical Considerations.—I shall give a description of the apparatus I have used for the tests which led me to adopt the opinions I now hold, but as this might be described as the technical part of my article, I may conveniently give here a short explanation of how the introduction of a canyon in the response curve can suppress (or rather, not allow to be created) unpleasant and unmusical noises. It would become very complex and difficult to deal with the whole gamut of musical sounds played simultaneously by a large orchestra, just as difficult as trying to give equations showing how the single diaphragm of a loudspeaker can make a noise like an orchestra. A simpler example can be discussed—surface noise with records.

I have pointed out that surface noise is likely to become very noticeable and strident if there is a peak in the speaker or the pick-up (I assume that linear ampli-

fiers are not difficult to make). It can be shown, too, that in the absence of peaks or resonances the surface noise is not particularly prominent. The former effect is due, in large part, to the fact that a loud note emitted as a fundamental by the peak, modulated as it were by the surface noise, will create new upper harmonics if sufficiently intense, and new subjective tones, either summational or differential, with other tones already present in the reproduction (see any standard textbook on sound). With a flat response curve, I have also noticed that the comparatively gentle hiss of surface noise appears to form subjective tones with other tones present in the reproduction, and it seems reasonable to suppose that these new spurious tones are the cause of what a keen ear usually puts down as harmonic distortion in high-fidelity reproduction. What happens is that new harmonics are added to the harmonic range of the musical instruments, and the musical artist at once says there is something wrong.

Surface noise, if not exactly "aperiodic," like atmospheric in radio reception, is present over a large part of the frequency spectrum. The more critical part is between 2,000 and 8,000 cycles per second; but if we suppressed all harmonics we should also suppress the wanted music. The more prominent interferences can be located and suppressed by mov-

This point is not the same with all records nor even with records of the same make; it can only be found by trial, and it is an interesting experience to notice how the character of the surface noise changes as one or another harmonic is suppressed. Finding the best setting is part of the art of sound synthesising in the home.

The Rejector Circuit. — The simplest way of injecting a sharp dip into the response curve is by using a rejector circuit. Fig. 1 shows two forms. The tuned circuit $L C_1$ must be fairly low-loss, and this is not too easy to achieve since the inductance of L is appreciable. C_1 can be a 0.0005 μF variable air-dielectric condenser, and L should have an inductance of 2.5 to 3 henries and be air-cored. It is possible that a suitable design could be worked out with high-permeability core material, but I have not actually made such an inductor. The coil should be section-wound to keep down self-capacity and the wire should not be finer than 36 SWG. As several tapings are required (six spaced equally throughout the coil) it is probable that trouble would be experienced in bringing these tapings out of the condensed winding of a high-permeability design.

Fig. 1(a) shows the better arrangement. An eight-way switch is connected to the two ends and six taps of the coil, and the variable condenser across the

first tap of the coil, the rejector circuit will cause a very sharp dip of about 28 db. to appear in the response curve of the amplifier, as shown in Fig. 2, curve A, where

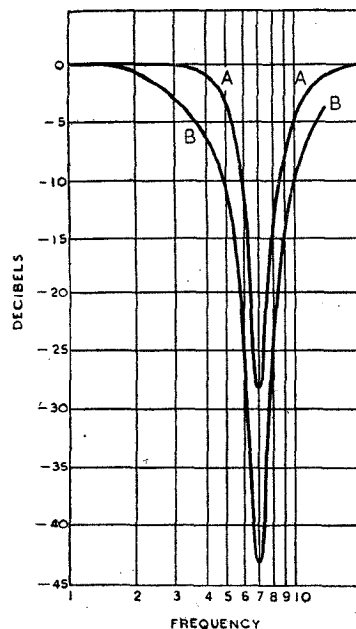

Fig. 2. Response curves of rejector circuit. Frequencies are marked in kilocycles.

the point of maximum attenuation is shown at 7 kc/s. By adjusting C_1 this point can be moved (with a 3 henry coil) over the range 4 to 10 kc/s. When the switch arm is connected to the free end of the tuned circuit, the dip will be like curve B in Fig. 2. If the reader happens to possess a suitable coil which is not tapped, it can be connected as in Fig. 1(b), where R_2 can be 5,000 to 10,000 ohms and R_3 is a variable resistor of 100,000 ohms. The arrangement of Fig. 1(b) is infinitely variable, of course, but I have found it convenient to have the adjustment in steps, as it is usual to find that a certain record requires one particular tap, and it is a simple matter to mark each record with the number of its best tap. The rejector circuit is put out of use by moving the switch to the beginning of the coil.

The top-cutting circuit $C_2 R_1$ is never used except with old or worn records and for special effects. C_2 should be 0.02 μF and R_1 100,000 ohms. With R_1 at maximum, the effect of the circuit is negligible; with R_1 at minimum resistance

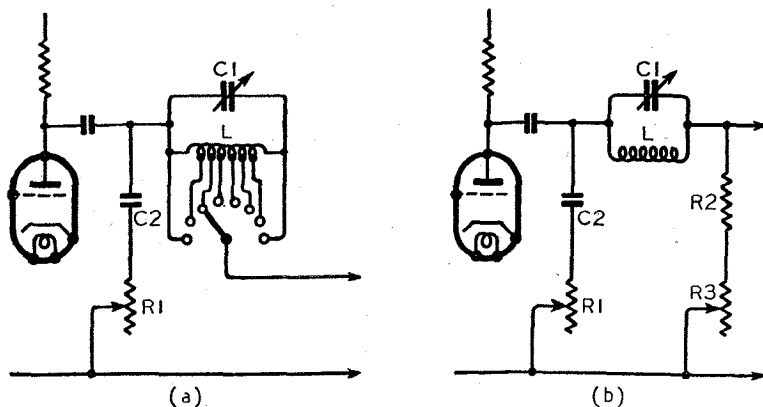

Fig. 1. Two forms of rejector circuit for introducing a variable sharp dip in the response curve of the amplifier.

ing our deep canyon up and down the frequency scale. At a certain point the surface noise will drop suddenly, and the extreme treble will instantly become cleaner.

whole of the coil. The fixed vanes should be connected to that end nearest the previous valve anode coupling condenser. When the switch arm is connected to the

Aesthetics of Sound Reproduction—the loss of top is severe. It is amusing to use this top-cutting circuit with organ records on which there is little or no playing on reed pipes. The flute stops of the organ have a limited harmonic development and are not spoiled by loss of top, but with reduced top and increased volume the pedal bass can be reproduced in a manner which is thrilling, provided the speaker can stand it without overloading.

Two rejector circuits in series might be used, to give two sharp dips in the response curve. A greater measure of conductorship could thus be applied to the music, but great care would have to be exercised, for if the two rejectors were tuned to fairly closely adjacent frequencies something like an inverted band-pass circuit would result, with distressing consequences from a musical point of view. One rejector circuit will be found adequate for ordinary requirements.

With practice, handling the rejector circuit control becomes quite easy. It is used in conjunc-

tion with the volume control and the top-cutting-off control (I cannot bring myself to using the expression "tone control") when the latter has to be used. The volume control is used, of course, to increase contrast, since the volume range on both radio and record is much restricted. Automatic contrast expansion just will not work because it cannot divine what is going to happen next. Detailed knowledge of what is on your records will enable you to do all the expanding you want, and with very artistic results, if done properly; but you cannot do anything about B.B.C. broadcasts. The only way to control their control engineer is to bludgeon him into insensibility. If the controls are going to be used continuously in this way, then provision should be made for getting them outside the cabinet, to keep pick-up chatter within its proper bounds. I have found flexible drives of the Bowden cable type, which can be pushed back into the cabinet, very convenient for this purpose.

(To be concluded.)

UNITED NATIONS STANDARDS

IT is learned from the British Standards Institution that it has been decided, as a temporary measure pending the return of full international co-operation, to establish a United Nations Standards Co-ordinating Committee to provide a centre for the immediate co-operation of standards in the field of communications of all kinds, both transport and telecommunication, and the development of standards for use in the transfer across borders of raw materials and partly or wholly finished articles. These standards will provide agreed methods of expressing and testing the properties of materials, appliances, symbols, terms and definitions, and will include dimensional standardisation to secure interchangeability where the replacement of parts is an important consideration.

The object of the Committee, which will have offices in London and New York, will be the promotion of the maximum possible co-ordination and unification of standards necessary for the war effort and the immediate post-war period. The promulgation of the standards will be the responsibility of the National Standards bodies of the United Nations.

"THE LONGEST WAY ROUND ..."

THE principle of avoiding zones of ionosphere disturbance by passing signals through relay stations situated in equatorial regions, as discussed in the May *Wireless World*, is employed by Cable and Wireless to increase the reliability of Empire communications. For several years, the difficulties of operating the London-Montreal circuit, which, by the direct path, encroaches on disturbed polar regions, have been avoided by relaying signals *via*

Ascension Island. A new relay station to serve both the London-Montreal and London-Melbourne circuits has now been opened at Barbadoes (B.W.I.). Perth (Western Australia) is also employed as a relay for the east-about London-Melbourne service. Still another relay station for this route is being built at Colombo, Ceylon. All these automatically operated short-wave wireless links are shown on the accompanying map.

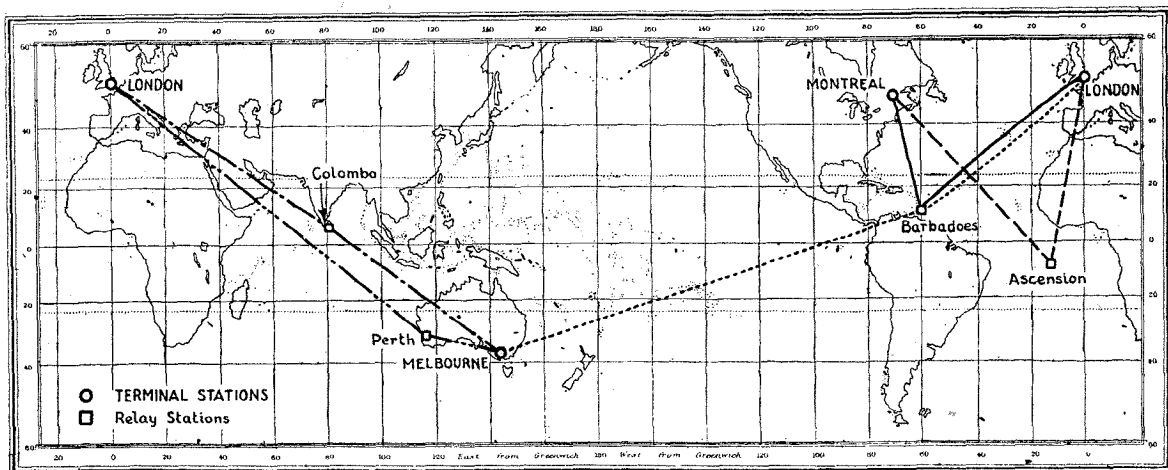

AUTOMATIC WIRELESS RELAYS. - Services operated by Cable and Wireless through telegraphic relay stations.

AUTOMATIC RADIO RELAYING

Some General Considerations

By D. A. BELL,
M.A.

THE successful operation of a long-distance line telephone system depends upon the use of numbers of unattended relays (repeaters), yet the idea of automatic relaying stations in a radio communication system is still looked upon as a somewhat daring innovation. In regard to television signals, some engineers still consider the relaying of the radio signal as more difficult than transmitting the video signal over a cable, in spite of the difficulties experienced on the London-Birmingham coaxial cable. What then accounts for so slow a development of radio relaying?*

One reason for the early development of closely spaced repeaters on line telephone systems was the need for an approximately constant level of speech power at all points in the system, so that there was no need for adjustments in the individual subscriber's apparatus for calls over different distances. This consideration has not so far been applicable to radio communications, because the greater inherent difficulties of operation have made it essential to retain human supervision of the communication channel and have caused terminal equipment to have a wide range of available gain. For example, the receiver in a short-wave radio telephone system will have a wide range of automatic gain control to counteract fading, but there is still the risk of abnormal propagation conditions in the ionosphere which would require the operator to intervene and transfer communication to another channel on a different frequency (if available). In radio working, therefore, the tendency is first to make the receiver as sensitive as possible so as to work to the maximum distance from a transmitter of given power. An additional gain of 6 db. in the receiver (2:1 in voltage sensitivity) would ideally be equivalent to doubling the field-strength; but the latter would involve a four-

* The so-called "radio relays," which distribute B.B.C. programmes by wire at audio frequency to individual subscribers, never were true radio relays, and some of them which obtain their programmes directly by land-line from B.B.C. studios now have no connection with radio at all.

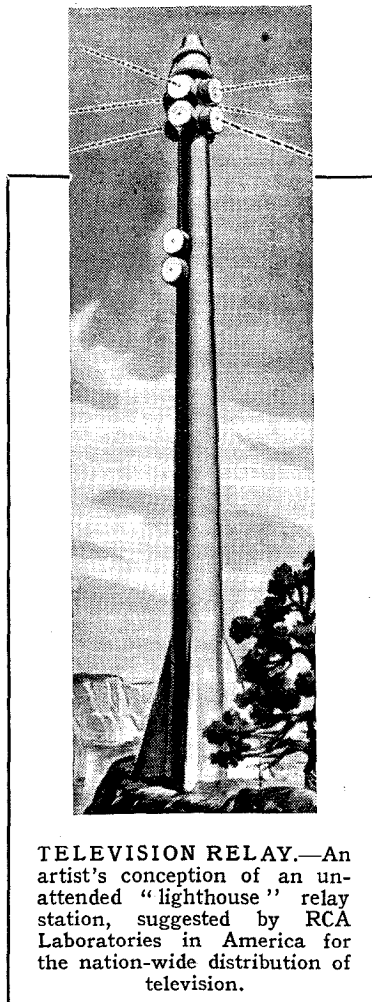

TELEVISION RELAY.—An artist's conception of an unattended "lighthouse" relay station, suggested by RCA Laboratories in America for the nation-wide distribution of television.

fold increase in transmitter power; e.g., from 25 kW to 100 kW, which would be far more costly than increasing receiver sensitivity. (Gain in received signal level through increase of transmitter power has been described as "gold-plated decibels" on account of the high cost.)

But a limit to useful receiver sensitivity is reached when it can handle a signal which is right down to the noise level; this level is set by different factors at different radio frequencies. Atmospheric and interference from

electrical machinery are dominant at the lower frequencies and the inherent noise level of the receiver at the higher radio frequencies. Here we have a fundamental problem of communication systems, which in line working is solved by the use of repeaters but in radio working has usually been solved only by an increase of transmitter power and directivity. The difference in tactics arises from a fundamental difference between the two systems; in a loss-free telephone wire the signal strength would not decrease with distance, but a radio signal in loss-free space would still show a decrease of amplitude with distance due to the spreading of the energy over a greater volume as the radius from transmitter to wave-front increases. If one installed a relay station with non-directional aerial half-way between a transmitter and receiver, most of the energy from the relay station would not go in the direction of the receiver, but in all other directions, including back to the transmitter. Of course one would use "beam" aerials if the wavelength were short enough, but there would still be a considerable spread of energy. On world-wide short-wave systems, another problem is to know where to put the relay station, since the signal may go one way or the other round the world according to which side is in darkness.

Since it has become possible to build high-power transmitters which would normally send signals to the far side of the world, there has not been much encouragement to build a chain of several stations, each of fairly high power, to do the same job; the occasions when long-distance communication was prevented by specially unfavourable propagation conditions were regarded as unavoidable natural events. Continued study of the ionosphere has brought a much greater understanding of such phenomena, and a more hopeful attitude; it is now proposed (see *Wireless World*, May, 1944, p. 140) to erect a chain of stations so that traffic

Automatic Radio Relaying—

which would formerly have been transmitted directly from one side of the world to the other, with a risk of occasional interruptions, can in future be passed over perhaps half a dozen shorter links, each of which will be very nearly 100 per cent. certain in operation. Greater reliability would be obtained by this system, but the operating costs might be higher.

An entirely different set of conditions holds when we come to decimetre and centimetre wavelengths. In the first place, their propagation is approximately optical, so that communication appreciably beyond the horizon (as seen from the top of the transmitting aerial) can only be secured by the use of relay systems; and the expense of increasing the range of a station on such wavelengths is not that of increasing the power but of increasing the height of the aerial mast or tower. Secondly, the directivity of aerials is so much greater that the system can be made to behave as a series of well-defined channels between transmitters and receivers, almost like a wire communication system. Finally, the amount of fading experienced is small (provided there are no large objects moving in the vicinity), so that there is little need for variations in receiver gain; this also resembles land-line conditions.

One of the difficulties of all radio relaying systems is to prevent feed-back between transmitter and receiver at the relay station, since this would cause oscillation. On the longer wavelengths the only solution is to use separate frequencies for transmission and reception, i.e., the signal changes its carrier frequency in passing through the relay station. For VHF working it has been suggested that the feed-back between transmitting and receiving aerials could be neutralised (Patent No. 541796, see *Wireless World*, June, 1942; p. 152), but usually a change of frequency will be the safer plan. An objection which has been raised to the relaying of television signals is that the signal would be detected in the receiver, amplified, and used to modulate a fresh transmitter on a different carrier frequency, and the processes of detection and modulation are both likely to introduce some distortion. But there is an alter-

native method; suppose the signal is received on a carrier frequency of 500 Mc/s, and it is desired to relay it on a frequency of 520 Mc/s. The 500-Mc/s signal could be given some RF amplification and then applied to a mixer valve together with a locally generated frequency of 20 Mc/s and the desired 520 Mc/s signal selected from the output of the mixer and amplified up to the required power for re-transmission. Besides avoiding the risk of distorting the modulation in the detection and re-modulation processes, this method reduces the frequency stability requirements at the relay station. For the local oscillator provides only 4 per cent. of the relayed carrier frequency, and so 1 in 10^6 stability of local oscillator would become 1 in 25×10^6 stability of relayed carrier.

There is therefore a good case for long-distance VHF communication systems based on highly directional aerials and automatic relaying stations at appropriate intervals. It has been suggested in this country that such a relaying system should be used for distributing our television services to transmitters in various parts of the country, and in U.S.A. frequencies of the order of 300 Mc/s are already used by sound broadcasting stations to replace telephone lines as the programme link between studio and transmitter. It had even been suggested in U.S.A. that a VHF communications network might grow up which would rival the ordinary line telephone networks. It is certainly a branch of radio which, in its various applications, should have an important future.

RANDOM RADIATIONS

—By "DIALLIST"—

Old Friends Again

AS I write, our long-awaited invasion of the Continent of Europe has just got under way. Like a good many others, probably, I heard the first news of its starting from a German station picked up by chance. In my excitement, I did not make a note of what station it was, so it may have been either a real German, or a station in one of the occupied countries broadcasting willy-nilly in that language. It may not be long—I hope it won't—before we have some of the old friends we used to know so well in Norway, Denmark, Holland, France and Belgium transmitting again in their own tongues all the time and sending out their own programmes instead of the unpleasant mixture prescribed for them by Dr. Goebbels and his minions. What a joy it will be to be able to tour round the medium-wave and long-wave bands once more and hear stations in liberated countries being their true selves again. It may be some little time, though, before they are all back with us, for many stations will be wrecked by the hazards of war or deliberately by the retreating Boche.

□ □ □

A Fresh Start

ONE thing that the war, or rather, the peace which follows it, should be able to do for wireless is to clean up and set in order the wavebands assigned to broadcast-

ing. You remember the pre-war semi-chaos, which conferences, plans and much hard work on the part of the U.I.R. had failed to straighten out? Many countries entered wholeheartedly into the various agreements and carried out their conditions in the spirit and in the letter; but there were others which were not so scrupulous and either didn't or couldn't make all the stations within their boundaries obey the rules. At the end of the war there will be a glorious opportunity of setting all this to rights and of forming a governing body for broadcasting in Europe as enlightened and as powerful as the Federal Communications Commission in the United States. One thing that most of us would like to see is a return to the original 10-kilocycle separation between channels: the 9-kc/s separation in operation when the war broke out was not sufficient to ensure decent quality or to prevent heterodynes.

The Way Out ?

How are we ever going to find a way of fitting the quart of European stations into the pint pot of channels available for them to operate upon?

Even if the fullest use were made of synchronisation and of common channels, I doubt whether any scheme could be devised which could make it possible for all the stations existing in 1939 to work without mutual interference on the medium- and long-wave bands.

Something may be done by reducing the numbers of stations in countries which had more than they really needed to give a satisfactory service; something, too, by increased compulsory use of directional or semi-directional aerials. Severe penalties for wavelength-wandering would help to some extent. But none of these things will provide a complete answer to the problem. What I hope to see is an increasing use of VHF high-fidelity relays, frequency modulated for choice, in all countries. It would be necessary for each to retain a few medium-wave or long-wave stations for the benefit of those who have receivers suitable only for these wavelengths and for amplitude modulation. But once the advantages of the VHF relay scheme (whether or not it is used in conjunction with vision broadcasts) are fully realised, and once the listener has come to appreciate the close approach to perfect quality of reproduction and the freedom from mutual interference obtainable with VHF, I believe that it will not be long before the bulk of broadcasting is done in this way. It seems the best and simplest of solutions of the European wavelength tangle. But there's a snag—and a big one: we can't make full and free use of VHF unless and until certain kinds of easily preventable man-made static are outlawed by Act of Parliament.

□ □ □

Aids to Memory

THE tip I gave last month about decimals of sevenths is a useful one that has served me in good stead. When I said that it came in handy when you are working with π , I meant, of course, that it did so only as long as $22/7$ is taken as a sufficiently accurate approximation to π for the work in hand. Though it gives you accurately the decimal for any number of sevenths from one to six, it obviously won't help if $22/7$ is not close enough. Talking of π , one reader sends me an ingenious way of remembering its reciprocal. All that you have to do is to ask yourself: "Can I remember the reciprocal?" The answer is in the number of the letters in those five words—3, 1, 8, 3 and 10: $1/\pi$ is 0.318310. That's one of the neatest that I've come across. What is curious is the number of readers who, in sending me tips about quick ways of doing mental calculations, give examples on paper—and get the answer wrong! The errors are always due to some little slip-up in the simplest of multiplications or additions. It's very comforting to find that others besides one's self are liable to these slight mental aberrations. I have an incurable habit, when what I'm

pleased to call my brain is getting tired, of adding instead of multiplying or vice-versa: five nines are fourteen and that kind of thing. Does anyone know a remedy?

□ □ □

AC and DC

HEAPS of readers sent in solutions of the Watte-Knowse problem: What would an accurate moving-iron ammeter record if it were passing simultaneously 3 amps DC and 5 amps AC? The majority got the answer right, but the wrong answer numbered not a few. Is it not a fundamental principle that when any number of currents of different frequencies are carried by a conductor the RMS value of the resultant current is the square root of the sum of the squares of their RMS values? Regard the DC component as AC of zero frequency and RMS value 3 amps, and there you are. Should you require proof that the rule is of general application you can obtain it by integrating over one cycle.

Another Problem

One correspondent sends me another problem which, though quite straightforward, may be of general interest. Here it is. One anode lead of a bi-phase mercury arc rectifier is carrying intermittent direct current in the form of square pulses of 100 amps. The duration of each pulse is 0.01 second and the interval between pulses also 0.01 second. Now, what is the minimum current rating of the anode lead cable? As the combined output is 100 amps, would a 50-amp cable be permissible for the individual anode lead?

□ □ □

Standard Terms

AN excellent article on the subject of standardised electrical terms appeared in a recent issue of *Electrical Review*. It pointed out the importance of using the correct, up-to-date terms, which have the advantage of meaning what they say and saying what they mean. Many of us (I know I'm guilty) pick up a wire-wound or composition component and say "this is a 20,000-ohm resistance." We should by rights refer to the concrete object as a resistor: it possesses the abstract property of resistivity and has a resistance of 20,000 ohms. So with inductor, inductivity and inductance; reactor, reactivity and reactance; conductor, conductivity and conductance and the rest. Old habits die hard and it is not easy to cure oneself of talking about coils, condensers and so on; but they are very loose terms after all, for a wire-wound resistor is a coil, and so, very often, is a lamp filament. The

word "condenser" is really, meaningless in electricity, though not in steam engineering. Another point made in the article is that the misuse of abbreviations of electrical terms is far too common. How often does one see MA for milli-ampere instead of mA, mfd. for microfarad (μF) and either Ω or $\text{m}\Omega$ for megohm ($\text{M}\Omega$)? Another misleading abbreviation is mc for Mc/s. The general use of accepted terms and abbreviations makes the reading of articles and textbooks far easier and is therefore to be encouraged in every way.

NEW "WIRELESS WORLD" BOOK

Guide to the Ionosphere

IN the "good old days" of wireless we managed to achieve long-distance communication before anyone really knew how electro-magnetic waves travelled to their destination. That fact was recently emphasised in a speech by Prof. G. W. O. Howe, reported elsewhere in this issue. But those days are past; now, a wireless man cannot go very far without at least a working knowledge of wave propagation—especially if he is concerned with waves of from, say, 10 to 100 metres in length and with a world-wide range. Indeed, we are reminded almost every day of the growing importance of the work of the "ionospherist."

A new book, issued from the offices of *Wireless World*, aims at imparting the kind of knowledge on this subject that is most widely needed. "Radio Waves and the Ionosphere," by T. W. Bennington, is believed to be the only book of its kind in existence. It sets out, in the author's words, to explain propagation phenomena in language as simple as is possible, without any mathematics. Though it is primarily written for the professional radio technician, it can, as Sir Edward Appleton says in a Foreword, be recommended as a friendly and well-informed guide to anyone interested in long-distance radio communication.

A good idea of the scope of this little book—and of its orderly and logical layout—can be gathered from the chapter headings: Ground Waves and Sky Waves; The Sun and the Ionosphere; How the Ionosphere is Sounded; Ionosphere Variations; Long-distance Transmission; Ionosphere Disturbances and Other Abnormalities.

"Radio Waves," which is illustrated by 27 figures, is issued by our Publishers, Iliffe and Sons Ltd., Dorset House, Stamford Street, London, S.E.1, at 6s. net; by post 6s. 4d.

NON-INTERFERING AC MOTORS

The Induction Type and Its Limitations

By

N. F. T. SAUNDERS,

B.Sc., M.I.E.E.

IT is often suggested that greater use might be made of the induction motor by manufacturers of small appliances. In the first place this type of machine has no commutator and cannot, therefore, be guilty of radio interference which arises from this source and, in the second place, its construction is much more simple and robust, which should result in cheaper first cost and a longer life without attention. Manufacturers of small appliances are not unaware of this situation and their designers are constantly examining the problem, but, unfortunately, the induction motor has certain disadvantages as compared with the commutator motor and it is the limitations imposed by these disadvantages which make it impossible to substitute the induction motor for the commutator motor in many directions.

Split-phase Induction Motors.—

The parts of a typical single phase $\frac{1}{4}$ h.p. induction motor are shown in the accompanying illustration. The stator is built up from laminations suitably held together, in the slots of which are wound coils of insulated wire. The stator may be wound for any even number of poles, although there are practical limitations to this, as will be explained later.

The rotor comprises a core of steel laminations through the slots of which pass uninsulated copper bars which are soldered or otherwise fixed to copper end rings, thus forming a solid indestructible mass. The single-phase induction motor has no inherent starting torque and, therefore, an auxiliary winding of some description must be provided to produce a modified two-phase field system during the starting period.

In the case of power motors such as that illustrated, it is usual to employ a starting winding which is wound in a similar manner to the main winding and either has a high resistance or else is connected in series with an electrolytic condenser so that its power factor is appreciably different from that of the main winding;

i.e., there is a phase displacement between the two windings. This auxiliary winding is cut out of circuit as the machine approaches full speed, generally by means of a centrifugal switch.

Smaller induction motors used for other purposes have a simplified stator construction, depending on performance requirements. For instance, in the case of a desk fan four salient poles are used so that the main winding is concentrated in one coil instead of being distributed around the periphery. A reasonable flux distribution in the air gap is obtained by making the curvature of the pole face a greater radius than the air gap so that the gap is a minimum at the centre of the pole and increases towards the tips. At a position approximately one third from the edge of the pole a slot is made. A single copper coil is put around this third of a pole and the current which is induced in this coil produces a secondary flux sufficient to provide a starting torque.

Speed.—The speed of an induction motor is a function of the frequency of the supply and the number of poles for which the stator is wound, and is given by the formula:—

$$N = \frac{2f \times 60}{p}$$

where N is the synchronous speed in r.p.m.; f , the frequency in cycles per second; and p = the number of poles.

In practice, however, the induction motor does not run at synchronous speed, except that on no load it does so very nearly. The machine runs at a speed slightly less than synchronous, the difference being called the "slip." The slip increases with the load until the point is reached where the motor is exerting the maximum running torque of which it is capable. In fractional horse power motors the slip at full load

is of the order of 5 per cent. to 10 per cent. In a $\frac{1}{4}$ h.p. four-pole 50-cycle motor, the synchronous speed is, therefore, 1,500 r.p.m., and the full load speed is about 1,420 r.p.m. In smaller machines, especially where the "shaded pole construction" referred to above is used, the slip is much greater. Thus the speed of a four-pole 50-cycle desk fan would probably be about 1,150 r.p.m.

Where it is possible to provide a supply of abnormally high frequency, an induction motor may be used at a high speed. For instance, in a factory where a large number of portable tools is used, it is quite an economical proposition to install a frequency changer to provide, say, 200 cycles, in which case small portable tools fitted with two-pole induction motors will have a synchronous speed of 12,000 r.p.m. In this case also a three-phase system can be used, and thus the starting torque difficulties which are present in a single-phase induction motor are eliminated.

Torque.—It has already been indicated that the major difficulty with the single-phase induction motor is to provide a starting torque. The means adopted depends on the load for which the motor is to be used. The lower the starting torque required, the cheaper can be the means for providing it. For instance, the motor which is used to drive a domestic refrigerator must have a high starting torque, and this torque must be provided without drawing an excessive current from the mains. Consequently the capacitor arrangement is used; i.e., the starting winding is connected in series with an electrolytic condenser. This is, relatively speaking, the most expensive arrangement. At the other end of the scale, where the load on the motor is a fan or something else where the starting torque required is very low, the cheap shaded pole construction is good enough, provided the loss of efficiency which results from its

being permanently in circuit can be tolerated.

Substitution of Induction Motors for Commutator Motors.—

To begin with, it must be clearly appreciated that the commutator motor used in small appliances is invariably a universal motor; i.e., it is designed to run on DC as well as AC. Although considerable progress has been made in the adoption of a standardised 50-cycle supply, one is often surprised at the extent to which DC is still found. Any manufacturer who decided, therefore, to adopt an induction motor to drive a certain appliance where a universal motor previously had been used would either be unable to supply customers on DC or else would have to run a separate design for DC, which would generally be found to be uneconomical.

Speed Limitation.—Not only does the commutator motor run at high speeds, but, in fact, it can only be designed as a really successful universal motor if it does run at high speeds. The speeds in question are of the order of 10,000 to 15,000 r.p.m. The maximum obtainable with an induction motor is 3,000 r.p.m., less slip, say, 2,800, but, in actual practice, it is found that a two-pole motor is more difficult to produce than a four-pole. Owing to the fact that the stator coils must span nearly 180 deg., the ratio of active material to inactive is less favourable, and it is also found more difficult to obtain a good starting and running-up torque. However, assuming that for any given application a satisfactory two-pole motor can be made, the speed would still be far below that at which a universal motor has been run. On a domestic vacuum

cleaner, for instance, the universal motor runs at about 8,000 to 10,000 r.p.m. It has been suggested that an induction motor could be used in conjunction with gears. The difficulties here would be the cost of the gears and the absolute necessity of ensuring that they would run without any attention whatever for many years without causing any trouble. It is probable also that they would increase the noise, which is already considerable. More likely solutions are either the use of impellers of larger diameter or a belt drive from the motor to the impeller. The latter would suffer from the disadvantage that the belt life is bound to be relatively short, and even if this item were easily replaceable, it would probably still constitute a vital objection.

Torque and Speed Control.—Although in some applications, e.g., for vacuum cleaners, the low starting torque of an induction

impossible to run at intermediate speeds. Apart from the fact that the speed-torque characteristic of the induction motor does not lend itself to speed control, as soon as the speed is brought down below the cut-out speed of the centrifugal switch, the starting winding comes into operation, and this cannot be allowed as the winding is only short-rated.

Weight.—Horse-power and speed conditions being equal, the induction motor is inherently rather lighter than a commutator motor, but if a comparison is drawn between an induction motor of a certain horse power running at, say, 2,800 r.p.m. with a universal motor of the same horse power running at, say, 9,000 r.p.m., the commutator motor is, of course, a very great deal smaller and lighter simply because it is developing the horse power at a very much higher speed. The consequence is that even if the low speed of the induction motor could be compensated for by the use of gears, a belt drive or some other way, the designer is still up against the difficulty of weight. In very many small appliances this would be an insuperable obstacle.

Synchronous Motors.—A synchronous motor is an AC machine which runs at synchronous speed. In the case of large machines (true synchronous motors) the rotor is excited

from a DC supply so that it presents alternate north and south DC poles to an AC stator. The result is that once it has been run up to synchronous speed it will carry its load at that speed. In the case of small machines, however, this arrangement is a practical impossibility. The so-called small synchronous motors, therefore, are not true synchron-

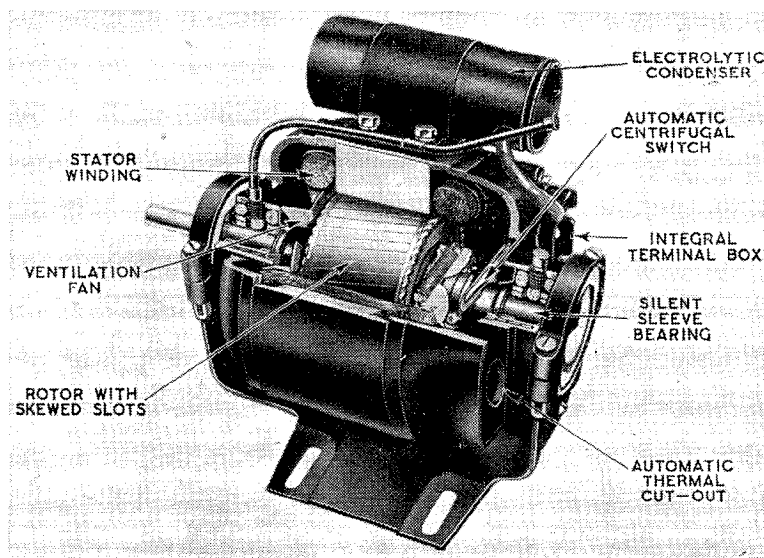

Cut-away view of a typical small induction motor, made by G.E.C., showing construction and salient features.

motor would not be an objection, in others it would. A more serious problem is that of speed control. There are many instances where small appliances are required to run over a range of speeds, and when a universal motor is employed this is easily arranged. A sewing machine motor is a good example of this. If an induction motor were employed, it would be

Non-interfering AC Motors—

ous motors at all, but rely for their operation by taking advantage of certain phenomena associated with rotating machines. The simplest example is that of the synchronous squirrel cage motor. If the rotor of the squirrel cage motor shown in the illustration is built up with pieces removed from the rotor core so that the core presents four salient poles, the squirrel cage winding being in position, it will be found that the motor will start up as an induction motor, but will run at synchronous speed. It will also be found, unfortunately, that at synchronous speed it will not develop more than about $1/12$ th

h.p. and if it is loaded beyond this, it will fall out of step and run as an induction motor at a slip speed, but owing to the loss of active material from the rotor it will be very inefficient and will not develop its original $\frac{1}{4}$ h.p.

In smaller motors still, e.g., those in electric clocks, very many ingenious "freak" designs have been produced. These generally rely on "cogging" effects which, in the case of large machines, are a nuisance to designers.

In the case of all these machines, however, the maximum power developed is very small indeed and, therefore, their use for anything but these very small applications is quite impossible.

BOOK REVIEW

Radio Technology, by B. F. Weller, A.M.I.E.E. Pp. 358; 113 figures. Chapman & Hall, 11, Henrietta St., London, W.C.2. Price 21s.

IN spite of the large number of books on radio which has been published during the last few years, there is still a definite need for something intermediate in size and standard between elementary expositions and full-sized text-books. With this volume Mr. Weller has made a very able attempt to fill this gap.

Fundamentals of the subject are provided by the first two chapters, the first dealing with resistance, inductance and capacitance, and the second with the generation and detection of electromagnetic waves. Considerable space is devoted, in Chap. II to coupled circuits. Chap. III introduces thermionic emission and describes the use of diodes for detection of modulated RF and mains rectification. Triodes, tetrodes and pentodes and their applications in detection and AF and RF voltage amplification are described next, and after a chapter on class A, B and C amplification, the author deals with oscillators, RF power amplifiers, quartz crystal control and their use in telegraph transmitters. Naturally enough, the next chapter (VII) on telephony transmitters deals with microphones, the broadcasting chain and modulation systems.

Receivers are next treated, Chap. VIII describing the "straight" and Chap. IX the superheterodyne types, and the final chapter deals briefly with propagation conditions and in detail with transmitting aerials and feeder systems.

The book has quite a high mathematical standard and several of the well-known differential equations are encountered in it. The diagrams throughout are excellent, although

one or two textual errors are present in some of them (in the captions of Fig. 3, p. 10 and Fig. 37, p. 116, for example).

Many books dismiss the large subject of transmitters in a few pages. The author deserves congratulations for producing a book in which equal space is devoted to transmitters and receivers. It is also extremely pleasant to see the subject of aerial feeder systems adequately treated. A somewhat unfortunate feature is, however, that the author has used the familiar and convenient "it can be shown" at least ten times in the first 30 pages in spite of his intention, voiced in the preface, to avoid this and equivalent phrases. In spite of the absence of any references to frequency modulation or television, which some may consider a serious omission, the book can be confidently recommended, and should prove a valuable contribution to radio literature.

S. W. A.

"MUSIC WHILE YOU WORK"

FOLLOWING an investigation of the effect of music in relation to repetitive manual work the American War Production Board has issued some interesting findings which are based on the result of a survey covering 100 war plants in all parts of the United States. Of the plants visited 76 were using recorded programmes for their music sessions whilst the remaining 24 employed either bands or orchestras mainly recruited from the staff. It should perhaps be pointed out that there are no broadcast programmes similar to the B.B.C.'s "Music while you work" shows transmitted in the United States.

Considerable space in the report is devoted to the effect of music on morale, production, etc., and to the length and frequency of programmes, but we will confine ourselves to a few technical findings.

It is stated that given efficient technical equipment and enough loudspeakers music was found to be perfectly audible to workers even above a noise level of 100 decibels, or more. The explanation is said to be that the ears of workers become attuned to the noise in which they work and which actually forms for them a background to the music.

The importance of maintaining the volume at a constant level is stressed, and to this end it is recommended that special recordings for reproduction in works should be made. Until such times as these are available in sufficient quantity the inclusion of a volume expander in the amplifier is recommended.

In many cases programmes were being relayed over PA systems originally installed for paging people through the works. These were, of course, found to be unsuitable as they are not designed for the wide frequency coverage necessary to reproduce music.

Books issued in conjunction with "Wireless World"

	Net Price	By Post
FOUNDATIONS OF WIRELESS. Fourth Edition, by M. G. Scroggie	7/6	7/10
TELEVISION RECEIVING EQUIPMENT , by W. T. Cocking	10/6	10/10
RADIO LABORATORY HANDBOOK , by M. G. Scroggie. Second Edition	12/6	12/11
WIRELESS SERVICING MANUAL , by W. T. Cocking. Sixth Edition	7/6	7/10
HANDBOOK OF TECHNICAL INSTRUCTION FOR WIRELESS TELEGRAPHISTS , by H. M. Dowsett and L. E. O. Walker. Seventh Edition	30/-	30/7
RADIO DESIGNERS HANDBOOK , Edited by F. Langford-Smith, B.Sc., B.E.	10/6	11/1
RADIO DATA CHARTS. Third Edition, Revised by J. McG. Sowerby, B.A., Grad. I.E.E.	7/6	7/10
RADIO INTERFERENCE SUPPRESSION , by G. W. Ingram	5/-	5/4
LEARNING MORSE. 335th thousand	6d.	7½d.
INTRODUCTION TO VALVES , by F. E. Henderson	5/-	5/4
RADIO WAVES AND THE IONOSPHERE , by T. W. Bennington	6/-	6/3

Obtainable from leading booksellers or by post from

LIFFE & SONS LTD., Dorset House, Stamford Street, London, S.E.1

Angles on **BRIMAR PRESTIGE**

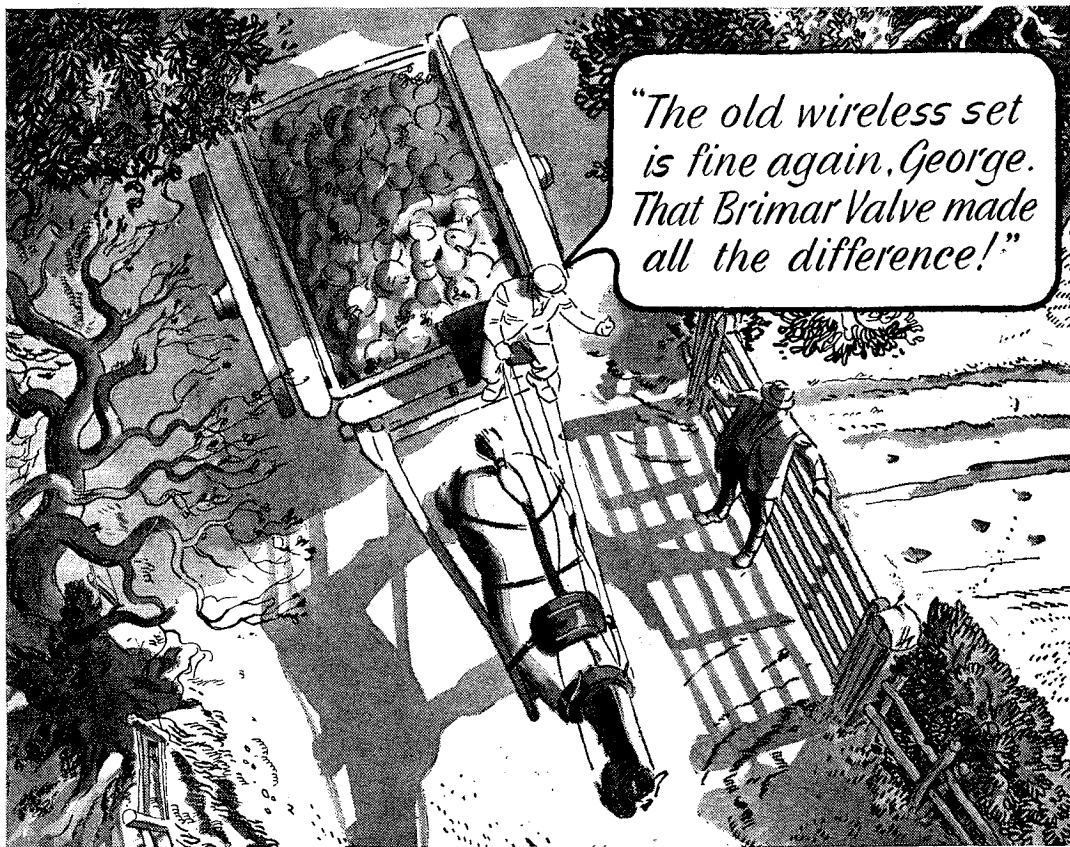

"All the difference" between indifferent and first-class radio reception is ensured by fitting the correct Brimar Valve.

BRIMAR
 (BVA)
VALVES

STANDARD TELEPHONES AND CABLES LIMITED, FOOTSCRAY, SIDCUP, KENT.

Exide

BATTERIES

FOR RADIO

are playing their part in the great national effort. They are as indispensable to the purposes of war as to those of peace

THE CHLORIDE ELECTRICAL STORAGE COMPANY LIMITED
Grosvenor Gardens House, Grosvenor Gardens,
London, S.W.1

RADIO DATA CHARTS-16

Voltage Gain of Resistance-Coupled Amplifiers

By

J. McG. SOWERBY,

B.A., Grad.I.E.E.

(By permission of the Ministry of Supply)

THE formula for the gain of a resistance-coupled amplifier (Fig. 1) is given by the relation

$$M = \frac{\mu}{R_a/R_L + 1} \dots (1)$$

Where

M = voltage gain,

μ = amplification factor of valve,

R_a = anode resistance of valve,

and R_L = load resistance.

This presupposes that μ and R_a are known for the valve in question, and this data is usually given by the valve manufacturer. By substituting the familiar valve relation:—

$$\mu = g_m R_a \dots (2)$$

where g_m = mutual conductance

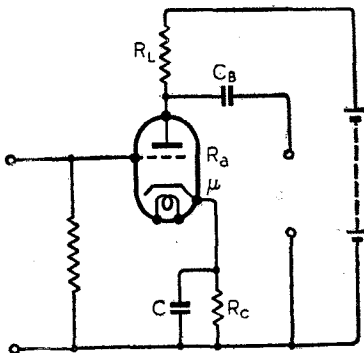

Fig. 1. Resistance-coupled amplifier, C_B is a blocking condenser and C a condenser whose reactance is low compared with R_C at the lowest frequency to be amplified.

of valve, into (1) we obtain the equally familiar formula

$$M = \frac{g_m R_L}{R_L/R_a + 1}$$

which may be reduced to

$$M = g_m R_L \dots (3)$$

when R_a is very large compared with R_L as is often the case when pentodes are used. This formula (3) will always give too high a result: 10 per cent. high when $R_a = 10R_L$, 1 per cent. high when $R_a = 100R_L$, and so on. In practice, valve manufacturers usually quote g_m and R_a for

pentodes, so that if equation (1)—on which the present chart is based—is to be used, μ must first be found from (2), and so the chart has been designed to cover this relation as well as (1). If (3) is sufficiently accurate in any given case, no chart is required, as the formula is so simple. Thus to calculate the gain of a resistance-coupled triode (μ and R_a known) the chart is used directly. To calculate the gain of a resistance-coupled pentode (g_m and R_a known) μ is first found with the chart and then the same procedure as for the triode is followed. This will be brought out in the examples.

Now suppose that to reduce distortion (or for some other good reason) negative feedback is used. The gain is then reduced to

$$M' = \frac{M}{1 - \beta M} \dots (4)$$

and for negative feedback β is negative. The chart is also designed to cover this formula when M and β are known, as well as (1) and (2). There are many ways of producing negative feedback and controlling the fraction, β , of the output fed back in anti-

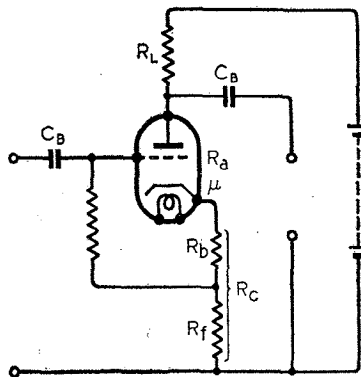

Fig. 2. Single-stage amplifier with current negative feedback—general case. R_b = bias resistance, R_f = feedback resistor.

phase to the signal at the point of application. Moreover, there are two main kinds of feedback—known as current and voltage feedback. Current feedback is usually applied only to one stage,

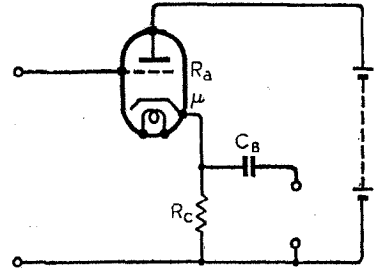

Fig. 3. Cathode follower whose gain is always less than 1.

as shown in Fig. 2, and the gain is given by

$$M' = \frac{\mu R_L}{(\mu + 1)R_C + R_a + R_L}$$

This gain may be calculated another way, which is more convenient from the point of view of our chart. If the gain M is first calculated by (1) it may then be modified by (4) by taking the feedback factor as

$$-\beta = \frac{\mu + 1}{\mu} \cdot \frac{R_C}{R_L} \dots (5)$$

which, when $\mu \gg 1$, may be reduced to

$$-\beta = \frac{R_C}{R_L} \dots (6)$$

with only a small error. It should be noted that this value of β for current feedback may only be applied to the calculation of gain, and may not be used indiscriminately in other voltage feedback formulae. In the case of the cathode follower (gain always less than 1) the gain may be found by calculating as if R_C were the anode load, and modifying by (4) taking $-\beta = 1$. A cathode follower stage is shown in Fig. 3.

A single stage with negative voltage feedback might be connected as shown in Fig. 4, and here β is given by

$$-\beta = \frac{R_1}{R_1 + R_2}$$

(Concluded on page 211)

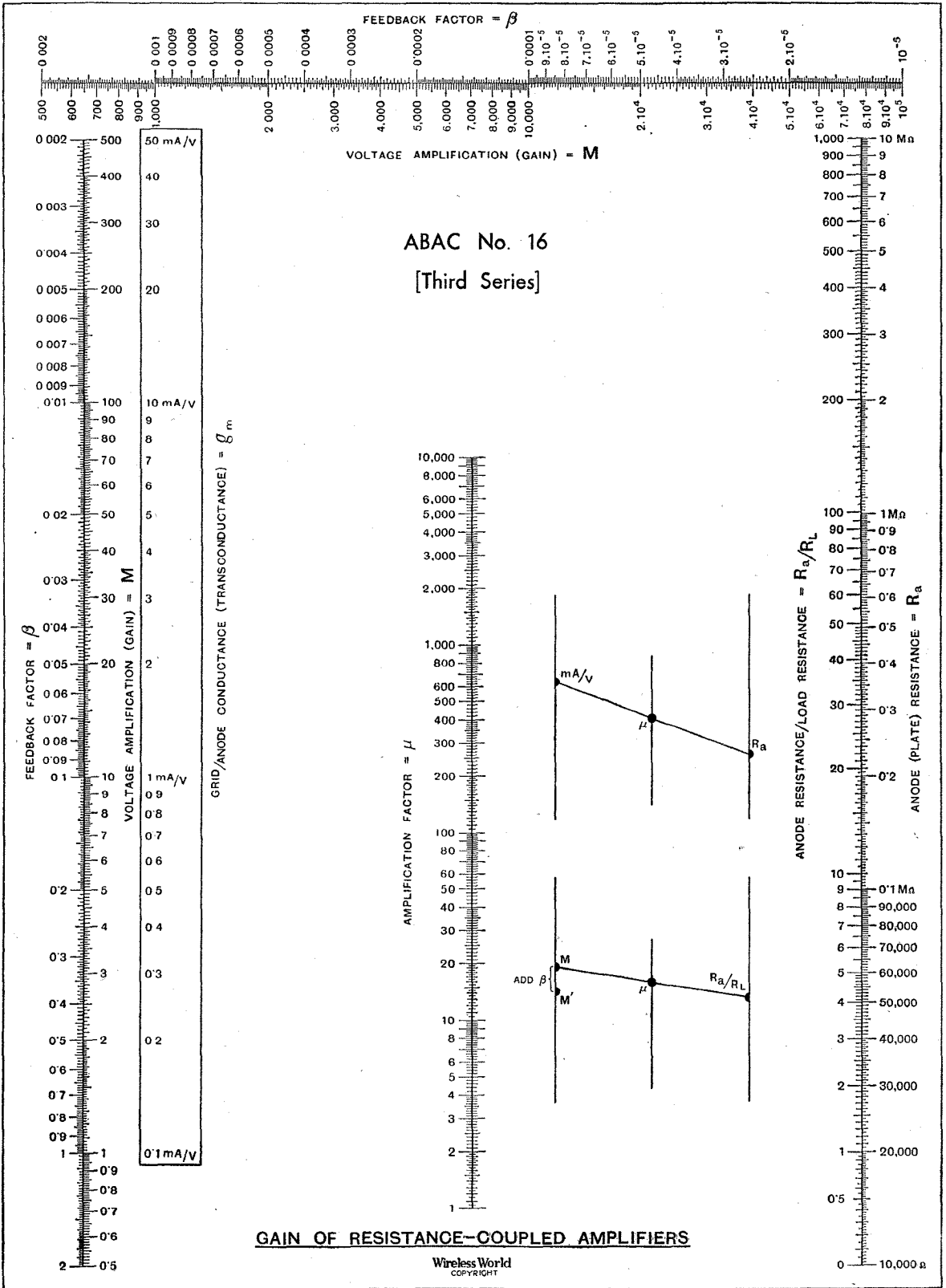

Radio Data Charts—16

and M' may be found from (4) when M is known.

Inspection of the chart and examples show that to find M' when M and β are known, only a pair of adjacent scales are used, and so these have been extended to cover gains greater than would be met with in a single stage, so that the effect of feedback on multi-stage amplifiers (Fig. 5) may be found. The gain without feedback may be found by multiplying the gains of the individual stages together in the usual way, and these individual gains may be found from the chart. The feedback factor ($-\beta$) will depend on the arrangement chosen, but can usually be made dependent only on the ratio of a pair of resistances.

EXAMPLE 1.—Let us first use only the β and M scales to find the effect of feedback on gain.

A multi-stage amplifier has a gain of 2,000 without feedback. Negative feedback is applied from output to input so that $\beta=0.0035$. What will the new gain be?

Opposite 2,000 on the M scale is 0.0005 on the β scale. Adding 0.0035 we obtain 0.004, and opposite this is 250 on the M scale—the new gain.

Now suppose that (due to ageing of valves, etc.) the gain without feedback falls to 1,500. Then opposite 1,500 is found 0.00066. Adding 0.0035 we obtain 0.00416, and the corresponding

EXAMPLE 2.—A triode of $\mu = 34$ and $R_a = 11,000\Omega$ is loaded with $60,000\Omega$. What is the gain?

which is the gain with the 900Ω bypassed). Now find the feedback factor, which is very nearly

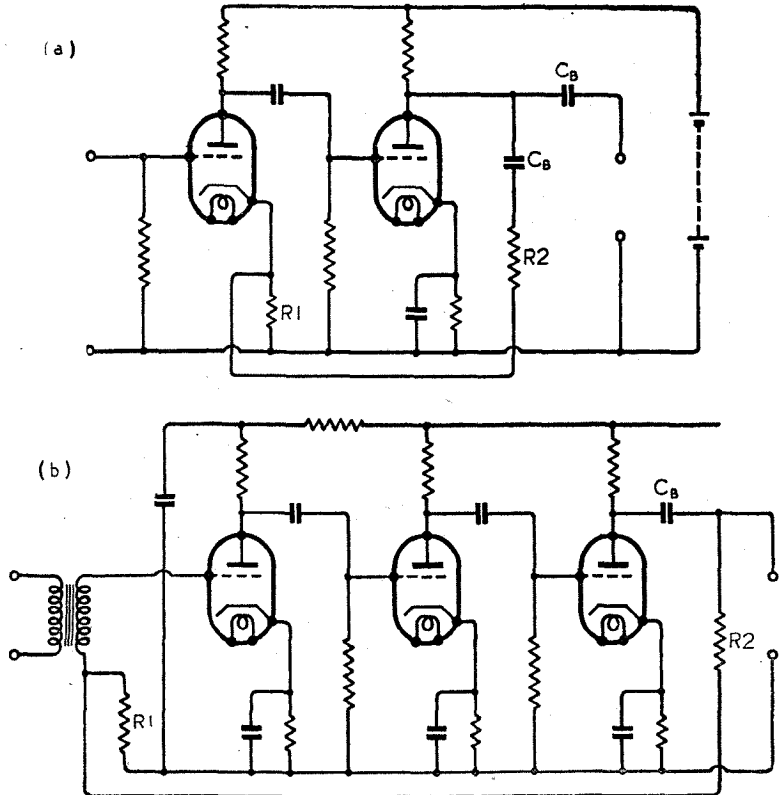

Fig. 5. (a) Two-stage feedback amplifier. (b) Three-stage feedback amplifier. The feedback depends on R_1 and R_2 .

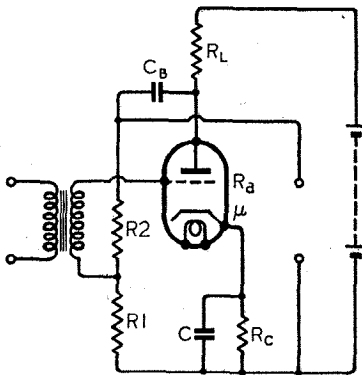

Fig. 4. Single-stage amplifier with negative voltage feedback.

gain is just under 240. Thus a change of 25 per cent. in valve performance results in only 4 per cent. change in gain, and so considerable stabilisation has been effected—though at the expense of gain.

$$\text{Now } R_a/R_L = \frac{11,000}{60,000} = 0.1835.$$

and joining this to $\mu = 34$, the chart gives $M = 28.7$, which is the required gain.

EXAMPLE 3.—A pentode of $g_m = 1.2$ mA/volt and $R_a = 1.25$ M Ω is loaded with $150,000\Omega$ ($= R_L$) in the anode and 900Ω cathode bias resistor (not bypassed). What is the gain?

Now $R_a/R_L = 1.25/0.15 = 8.34$. Joining $g_m = 1.2$ to $R_a = 1.25$ we find $\mu = 1500$. Joining $\mu = 1500$ to $R_a/R_L = 8.34$ we obtain 0.0062 on the β scale (opposite is 161,

$900/150,000 = 0.006$. Adding, we get $0.006 + 0.0062 = 0.0122$ and opposite this on the β scale we find the required gain to be 81.9.

COVER ILLUSTRATION

OUR cover illustration is from a photograph taken at the E.M.I. Recording Studios and shows a recording head cutting a wax blank. The wax thread is removed by suction and is seen entering the tube. Note also the test cuts on the extreme edge of the wax which are made to check the accuracy of the depth of the groove.

AMPLIFIERS : DESIGN DATA

It is regretted that all back numbers of *Wireless World* containing constructional information on high-quality AF amplifiers are now out of print. The only publication on this subject at present available is a reprint of an article describing war-time versions of the *Wireless World* Quality Amplifier. This leaflet is obtainable from our Publishers for 4½d. by post.

RADIO HEATING EQUIPMENT

IV. Interference Problems : Importance of Efficient Screening

IT is probable that within a very few years many tens of thousands of kilowatts of radio power will be generated in this country for industrial heating. The rapid growth of radio heating in America is typified by the case of one industrial plant concerned with the tin plating of steel, in which over 3,000 kW of radio power is used for heating.

It is essential to ensure that the enormous RF power which will be utilised for industrial purposes is not radiated to any appreciable extent. Great though the advantages may be in applying radio power to some heating processes, it must not be forgotten that the application which confers the chief benefit is undoubtedly in the field of communications.

There has been some talk of the possibility of certain frequency bands being allocated exclusively for radio heating equipment. No precaution against radiation would then be required, but it would be necessary for the frequency accuracy and stability of the equipment to be of a high order.

If this scheme were adopted, the master oscillator—power amplifier type of generator would have to be employed, and there are disadvantages accompanying the use of such equipment. The power amplifier containing the "work" in its anode circuit would need to be tuned accurately to the frequency of the master oscillator to ensure efficient operation. For most "work," however, the tuning will change rapidly during the heating cycle, a very sharp change occurring with magnetic "work" as the Curie temperature is approached.

Difficulties of Frequency Control

The desirability of the automatic time control of the heating cycle has been mentioned earlier, but, when the rate of heating is controlled manually by an operator who is endeavouring to maintain the amplifier in tune, it is doubtful whether the heating time will be uniform for repetition work. There is, of course, the

By

L. L. LANGTON,

A.M.I.E.E.

possibility of having a generator sufficiently powerful to induce heat fairly rapidly, when somewhat mistuned, and under these conditions, a consistent heating time for repetition work could be achieved with reasonable ease.

Were it possible to maintain the amplifier in accurate tune, by automatic means, the full power could be utilised at all times. Unfortunately, the normal electronic method of automatic tuning, which depends upon the variation of interelectrode capacity of a valve due to the Miller effect, is not practicable when applied to circuits of large power. Again, the variation in tuning required when heating some "work" would be outside the range of such a device. It may, of course, be possible to achieve automatic tuning by a complicated and costly electro-mechanical system.

Another difficulty occurs when the amplifier works at very high frequencies, for the tuning capacity of the tank circuit would then consist of the valve interelectrode capacity and other strays. Owing to the varying potentials applied to the valve electrodes during operation the Miller effect would cause a frequency spread, which may result in an appreciable reduction in the output, due to mistuning.

The allocation of fixed frequency bands would be a limiting factor in the usefulness of radio heating, as there is an optimum frequency for the most efficient heating of given "work." The selection of the optimum frequency for "work" of given diameter assumes some importance at high temperatures when the permeability of magnetic material falls to a stable low value, and in all cases where non-magnetic material is to be heated.

The use of the more rugged self-excited power oscillator with no restriction on the frequency of operation is obviously to be

preferred from the industrial standpoint. If reasonable care is exercised in the design, such as the recommendations regarding filters mentioned in the previous article and the advice on screening which follows, no undue amount of interference should occur.

Electrostatic Screening

External electrostatic fields may be suppressed by placing the generator in an earthed metal cabinet, the high conductivity of which ensures that it always presents an equipotential surface.

The electrostatic screening effect of a metal sheet is not affected by holes or long narrow slots, provided that the conductivity of the material is high. At very high frequencies the resistance of the material increases, and there will no longer be zero potential difference over the surface. The screening effect under such conditions is reduced, and double screening will be required with the outer screen situated not less than 1 inch from the inner one.

The rapidly varying magnetic flux set up by the oscillator induces eddy currents, which will flow in a layer of the cabinet material. The thickness of this layer will be proportional to the square root of the specific resistance of the material and inversely proportional to the square root of the frequency. The magnetic flux due to these eddy currents will, by Lenz's Law, oppose the primary flux creating them, and magnetic flux existing exterior to the cabinet will be negligibly small. The magnetic screening of the cabinet will not be affected by the presence of holes, provided that their diameter is very small compared with the wavelength of oscillation. Slots in the cabinet, however, may pass radiation if they are parallel to the lines of magnetic flux set up by the oscillator tank circuit.

The presence of the cabinet surrounding the tank coil will have the effect of reducing the inductance, while increasing the effective resistance of the tank coil, after the manner of shorted turns

coupled to it. A reduction in "Q" will normally result, but there are isolated cases where the damping is largely imposed by dielectric losses exterior to the coil, and in these instances the presence of the screening cabinet may improve the value of "Q." The interposition of a high conductivity screen between the tank coil and large masses of high resistivity ferromagnetic material, which may unavoidably be in close proximity to the oscillator, may also result in an improvement of "Q."

In both electrostatic and electromagnetic screening, the containing cabinet must be of high conductivity material, in the one case to ensure that no unduly large potential difference may exist over its surface, and in the other to create a low-impedance path for eddy currents. The cabinet must be constructed of sheet metal, perforated or expanded metal or wire gauze. The Post Office recommendations are that the size of the mesh of the perforated or expanded metal should not exceed three-sixteenths of an inch, while for wire gauze the size of mesh should be not greater than one-quarter of an inch, and the wire not thinner than 25 SWG. The bonding between sides or sections of the cabinet must, of course, be as electrically perfect as is possible, or the objective of efficient screening will not be attained.

The RF power must, in many cases, be brought out of the screening cabinet, and the leads and "work" coil or application electrodes will radiate. Two factors control the degree to which radiation will take place, namely the radiation resistance of the external system and the current flowing in it. The radiation resistance is proportional to the square of the ratio between the distance separating current carrying conductors and the wavelength of operation. It is thus advisable to have no widely-spaced unscreened circuit carrying RF currents.

With eddy current heating, the

"work" coil forms an antenna, the radiation resistance of which is proportional to the square of the diameter and, to a somewhat lesser degree, to the number of turns on the coil. Since, in practice, the diameter will usually be very small compared with the wavelength of operation, there is likely to be no undue radiation. If the "work" is at some distance from the generator (an inadvisable arrangement), the leads to the "work" coil may consist of two parallel wires, and the radiation from these will largely cancel. The radiation resistance of a parallel wire non-resonant transmission line may, in fact, be regarded as the same as that of a single wire antenna, the length of which is equal to the separation between the wires. Since this distance will be negligible compared with the wavelength of operation, radiation will normally

any distance from the generating cabinet (again inadvisable), it is better, from the point of view of reducing radiation, to employ a concentric conductor, as the outer sheath forms an effective screen. The "work" electrodes at the far end may, nevertheless, have to be contained within a suitable screen.

In the heating of plywood and other large-scale "work," the electrode spacing may well approach a half wavelength and, with the large power employed for such purposes, radiation would be very considerable. The room or cubicle containing the "work" would then have to be screened in accordance with the recommendations to be found in the Post Office Engineering Instructions, Radio Interference, C1101, which is obtainable on application to the Engineer-in-Chief's Office (Radio Branch), G.P.O., Harrogate.

Although the lower frequencies used for ECH tend to restrict radiation, trouble may arise if the output of the generator has a large harmonic content. The use of the push-pull circuit, giving better waveform on load together with the suppression of even harmonics, is thus to be recommended. The "Q" value of the tank circuit when loaded has a large effect upon harmonic generation, and it may sometimes be advisable to work with a higher loaded "Q" value to limit the harmonic power, although there will, of course, be a

reduction in the efficiency of the generator if the optimum value is appreciably exceeded.

Any radio heater that is installed will require to be approved by the Post Office. Under present conditions, equipment generating over 10 watts of power at a frequency exceeding 10,000 c/s is controlled by the Defence Regulations. Such equipment may only be possessed or used by a person holding a Post Office permit to do so. Permits are issued when the Post Office is satisfied with the screening arrangements.

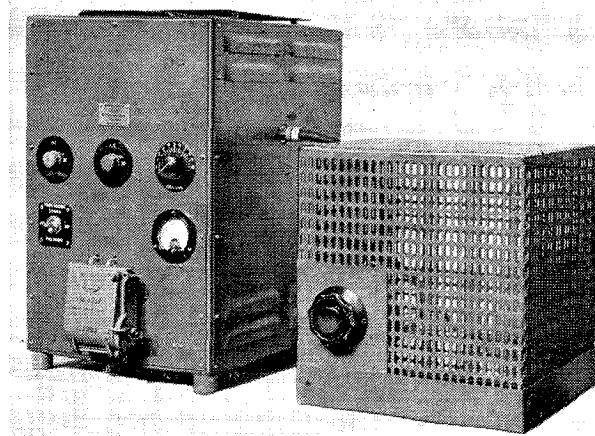

Type RH2, 250-watt radio heater by Rediffusion Ltd., suitable for experimental and small scale dielectric heating. The screened work chamber is connected to the RF generator by a concentric cable and a mechanical locking device is used to cut off the power before the screen can be opened.

be very small. It is as well to bear in mind, however, that the capacities of the leads to earth may not be exactly balanced, and in high-powered installations this may result in appreciable radiation.

With dielectric heating, the higher frequency of operation increases radiation difficulties, but to pre-heat plastics for moulding, it is usually possible to have the "work" electrodes in an effectively screened hinged cage on the side of the cabinet. If, however, RF power is to be taken

NEXT SUNSPOT CYCLE

Low Maximum Activity Predicted

SUNSPOT cycles are of some interest to radio men because of the fact that the ionisation of the upper atmosphere, which controls the frequencies usable for short-wave communication, varies in sympathy with them. During 1944 the present cycle is expected to come to an end, and indications of the beginning of a new cycle have already been observed by the astronomers, some of which were described in this journal earlier in the year.¹ But we cannot be at all sure about the exact time of minimum sunspot activity, nor about the way in which the solar activity will vary after the minimum is passed.

However it is interesting to learn the latest ideas upon this subject, and A. H. Shapley has recently given his views in an

high-latitude sunspot (all the spots of the old cycle appear in low solar latitudes towards the end of the cycle). In the case of the coming cycle Shapley considers this to be a small spot which was observed for one day only in Lat. 32 deg. on Dec. 20th, 1942. Thus, using the decimal date system, he makes the beginning of the new cycle $B=1943.0$.

In order to estimate the sunspot number at the next maximum, which is the next step in making use of the formulæ, he examines the maximum sunspot numbers for the past hundred years, and finds that a high maximum was always followed by a low maximum during this period. The sunspot numbers show, in fact, that there were nine highs and eight lows alternating, the last maxi-

1944.9 as the date of the coming minimum.

Shapley then gives the curve of sunspot activity as evidenced by the yearly relative sunspot numbers from 1900 to 1943, and also the trend of sunspot activity from 1944 to 1950 as estimated from the epochs and height of maximum which he has derived. This is reproduced in the accompanying diagram.

The author points out that not only the formulæ of Brunner, but also his own estimate of the height of the next maximum, contain many uncertainties. This is seen to be so if the sunspot cycles are examined for a period prior to the maximum of 1848.1, the first maximum used in the derivation of the high to low ratio of 1.48. Before 1848, not only would the ratio of high to low appear to be quite different, but also the very principle of alternating high and low maxima would appear to be completely upset. But whether this is due to any defect in the methods of recording or observing the sunspots prior to that date it is hard to say, but certainly there is that possibility. Anyhow, Shapley's concluding remarks constitute very sound advice; i.e., that his results should be regarded rather as an indication than as a definite prediction. As such, they should be of some considerable use to short-wave radio men.

T. W. B.

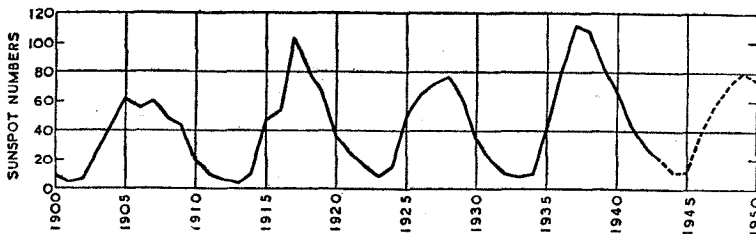

Observed and predicted relative sunspot numbers : 1900-1950.

article appearing in *Terrestrial Magnetism*.² He makes use of formulæ recently derived by Brunner relating the epoch of maximum and minimum sunspot activity with the epoch of commencement and the height of maximum of a sunspot cycle. Brunner considers the time lag between the beginning of a cycle and the epoch of the succeeding maximum of sunspot activity, and this time lag may also be compared with the height of the maximum as given by the sunspot numbers, and with the interval between the maximum and the preceding minimum.

To make use of the formulæ it is first of all necessary to determine the time of the beginning of a cycle, and this is taken to be the date of appearance of the first

maximum being that of 1937.4, which was a high. The ratio of each high maximum to its succeeding low was very similar, and the mean of the ratio high to low for the eight cycles was 1.48. The sunspot number at the maximum of 1937.4 was 119, so Shapley estimates the sunspot number at the next maximum by taking $\frac{119}{1.48}$ giving $R_M=80$.

If this figure is inserted into Brunner's equations it is found that T (time lag from appearance of first spot to epoch of maximum) = 6.6, and T' (time from maximum to preceding minimum) = 4.7. Thus, to find the date of the next sunspot maximum and also that of its preceding minimum, we have $E_M=(B+T)=1943.0+6.6=1949.6$ as the date of the next maximum, and $E_m=(E_M-T')=1949.6-4.7=$

¹ 1944: Sunspot Minimum Year," *Wireless World*, February 1944.

² "An Estimate of the Trend of Solar Activity, 1944-50," *Terrestrial Magnetism*, March 1944.

no lack of ideas on the subject.

Most of the complexities of reception are brought about by the need for counteracting the three forms of distortion to which the received signal is liable. Straight-forward fading and the effects of interference are comparatively innocuous; most of the trouble is due to "phase distortion." This is caused by arrival of the signals over transmission paths of varying length, and is more generally known as "multi-path" or "multiple effect." Even at the comparatively low speed of 125 w.p.m., the length of a dot is only 10 millisees. and distortion is such that the length of a signal element may vary by 20 per cent. or more of its true value. Normal maximum speed is 200 w.p.m., but in exceptional cases 400 w.p.m. has been achieved.

BRIT.I.R.E. REPORT

THE first part of a report on "Post-war Development in Radio Engineering," issued by the British Institution of Radio Engineers, surveys the probable trends of progress in the main branches of radio science. It opens with a plea that the Government, after considering the various reports on post-war planning, should encourage those industries offering the greatest prospect of national well-being.

Points from the report:—

Broadcasting.—A frequency-modulated UHF broadcasting service is a desirable supplement to the existing transmissions. In any case an early Government statement on transmissions systems is desirable, in order that receiver production may be planned. As a result of the war the export market for broadcast receivers will be greatly increased, but standardisation of valves and other components is necessary. Television proposals are given elsewhere in this issue.

Communications.—The war developments offer fruitful fields of application to peacetime uses. Establishment of relay chains on a single carrier frequency offers a means of alleviating congestion of the ether.

Industrial Electronics.—Many applications have been found during the war. In addition to controlling devices used in mechanical

To combat distortion troubles, elaborate receiving systems with diversity reception are employed. In spite of the use of AGC, there may be some fading of the signal passed to the recording unit; to secure constant amplitude, limiting is employed. These and other methods are described at length in the paper. It is pointed out that the bulk of traffic is handled by morse code, but automatic printing is on the increase.

Discussing future developments, the authors pointed out that the "on and off" nature of telegraphic signalling, with the absence of radiation during space intervals, aggravates the various forms of distortion. Frequency changing, or what may be described as frequency modulation, with continuous radiation, is considered to offer possibilities.

processes, electronics has been applied by the chemical industry to such operations as the control of hydrogen-ion concentration. Shades of colour can be matched by unskilled operators to limits beyond the capabilities of the human eye. Almost every kind of industry stands to benefit from electronics, but full realisation of its benefits will only come about if industry invites the co-operation of the electronic engineer to a greater extent than hitherto.

Government Control.—Control should not be restricted to the radio transmission of intelligence but should cover transmissions of an accidental type—"all electromagnetic radiations."

Standardisation.—Wartime standardisation of components for the Services should, in the main, be perpetuated after the war. Other components could with advantage be standardised, both in mechanical features and electrical qualities. The case of valves is of particular importance.

BROADCAST RECEIVER SPECIFICATIONS

A booklet entitled "Receiver Specifications and Prices" has been issued by *The Wireless Trader*, Dorset House, Stamford Street, London, S.E.1; price 1s. 6d. by post. It contains information on broadcast receivers manufactured between 1935 and 1940, and serves as a means of identifying sets and determining prices that may be charged for second-hand models.

GALPINS

ELECTRICAL STORES
"FAIRVIEW,"
LONDON ROAD, WROTHAM,
KENT.

TERMS: Cash with Order. No C.O.D.
All prices include carriage or postage.

MOTOR-DRIVEN PUMP, for oil or water, motor 220v. D.C., 1 amp., 1,250 r.p.m., maker Keith Blackman. **£6 10s.**

MASSIVE GUNMETAL WINCH, complete with long handle, for use with $\frac{1}{2}$ in. dia. wire cable, weight 50 lbs., condition as new. **£3.**

ELECTRIC LIGHT CHECK METERS, first-class condition, electrically guaranteed, for A.C. mains, 200/250 volts 50 cy. 1 phase 5 amp. load, **11/- each.**

SOLID BRASS LAMPS (wing type), one hole mounting, fitted double contact, S.B.C. holder, and 12 volt 16 watt bulb. **3/6 each, or 30/- per doz.**

TUNGSTEN CONTACTS, $\frac{1}{8}$ in. dia., a pair mounted on spring blades, also two high quality pure silver contacts, $\frac{1}{8}$ in. dia., also on spring blades, fit for heavy duty, new and unused. There is enough base to remove for other work. Set of four contacts, **5/-.**

RESISTANCE UNITS, fireproof, size 10 x 1 in. wound chrome nickel wire, resistance 2 ohms to carry 10 amps. **2s. 6d. each.**

3-PHASE TRANSFORMER, 410v. to 240v. at 2kW, size of core 14in. by 11in. by 5 square inch section. **£10.**

TAPE MACHINE, fitted Klaxon 220v. D.C. motor geared drive, rheostat control, 18 ohm relay, complete with tape reel and tape. **£10.**

AIR PRESSURE GAUGE by famous maker. 10in. dia., reading 0-4,000 lb. per square inch, as new, in case. **£7 10s.**

SWITCH FUSE in wrought iron case, 3-way, for 400 volts at 40 amp. **45/-.**

METER MOVEMENT for recalibrating, moving coil, 4in. scale, deflection not known. Price **20/-.**

MOVING COIL ammeter reading 0-350 amps., 6in. dia., switch board type. Price **£3 10s.** DITTO reading 0-20 amps. **£2 10s.**

H.T. TRANSFORMER, case 14 x 9 x 8in., no oil input 200/240v.; output 10,000 volts centre tapped, 3kW., intermittent rating. **£15.**

VIR CABLE, 200 amp., 19/33, in good condition in approx. 30 yard lengths. **£5 per coil.**

MAINS AMPLIFIER, 110/250v. A.C., approx. 5 watts, 3v., no valves, size of case 16 x 11 x 7in., metal rectifier H.T., by famous maker. **£5.**

TANGENT BELL, 250v. D.C., 12in. gong, weather-proof. **£4.** Ditto, 6in. gong for 110v. D.C. **30/-.**

ROTARY CONVERTER, D.C. to D.C. input 48 volts, output 2,500 volts at 1 kW., constant rating, as new. **£10.**

ROTARY CONVERTER, input 40 volts D.C., output 75v., 75 mA, A.C., also would make good 50v. motor or would generate. **£2.**

DYNAMO, output, 20v.-10 amp. Ball bearing, shunt wound, speed 1,750 r.p.m. **£5.**

AUTO TRANSFORMERS. Step up or down, tapped 0-110-200-220-240; 1,500 watts, **£7;** 1,000 watts, **£5.**

D.C. MOTOR. 12 volts (not car), approx. $\frac{1}{2}$ h.p., speed 1,500 r.p.m., large size. **£2 10s.**

H.T. TRANSFORMER, in case, size 10 x 7 x 6in (no oil), 200v. to 10,000 volts, C/T. output, 2½ KVA at 500 cycles, intermittent rating, **£8.**

WORLD OF WIRELESS

RECEIVER PRODUCTION

THE manufacture, and supply by manufacturers, of valve-operated broadcast receivers, are brought under control for the first time by the issuing of the "Musical Instruments and Wireless Receivers Order, 1944," by the Board of Trade. Manufacturers will be required to obtain licences permitting them to continue the manufacture and supply of sets after July 1st.

They will be required to apply the expression "Wartime Civilian Receiver" by means of a transfer to wireless sets made in accordance with specifications drawn up by the Radio Manufacturers' Association and approved by the Board of Trade. These words must not be removed or defaced by anyone, and may not be placed on any other wireless sets.

CAR RADIO

WITH the recent lifting of the ban on the installation of receivers in cars it may be necessary to remind readers of the licensing position.

Whilst the normal receiving licence for a fixed address also covers the use of one portable set by the licensee or a member of his household, a separate licence is required for a receiver permanently installed in a vehicle; it is not considered to be a portable.

FM STATIONS

IT is learned from an article in a recent issue of our United States contemporary *Broadcasting* that, in addition to the 51 FM stations at present licensed or under construction in sixteen States, the Federal Communications Commission has received during the past few months over 140 applications for new stations. Of this number 120 are from owners of existing AM stations whilst nearly 60 come from newspaper proprietors.

It is noteworthy that the proposed stations are for erection in 35 of the 48 States.

"TELCOM" FORCE

A NEW non-combatant Force is about to join the Empire's Forces in oversea theatres of war. It will be known as "Telcom" and will consist of men and women from the United Kingdom on the staff of Cable and Wireless serving in certain operational zones. Their task will be to carry the cable-heads and advanced wireless stations of the Empire's telecommunications network into enemy occupied territory close on the heels of the advancing armies.

They will help the Services to provide operational and administrative communications, handle messages from the forward areas for Government Departments and the Press, and handle social telegraph services between the troops and their families at home.

Men are already at their posts at Gibraltar, along the North African Coast, in Italy, in Malta and in Ceylon. The first contingent of the girls who are to follow them will leave Britain shortly.

TELEVISION STATUS QUO?

RECOMMENDATIONS on both sides of the Atlantic regarding post-war television point to a probable resumption of pre-war standards.

The annual report of the R.M.A., referred to elsewhere in this issue, includes findings by the Radio Industry Council on the reinstatement of television. The Council has submitted evidence on behalf of the industry to the Government Television Committee founded on the following three basic points:—

1. The television service existing when war broke out to be restarted as soon as possible after hostilities with Germany cease.
2. The resumption to be followed by an extension of the system over the rest of the country at the greatest possible speed.
3. Research and development to be carried out concurrently with the resumption and extension of the old system: the research work to be so planned that any resulting improved system may be begun and run concurrently with the existing transmissions.

Two pages of the sixteen-page report of the Brit. I.R.E. on the post-war development in radio engi-

neering, extracts from which are given on another page, are devoted to television. The view is expressed that the following characteristics in common with 1939 television standards should be included:—

- (1) That the service be "broadcast," i.e., there shall be a (generally) non-directional transmission without wires.
- (2) That the vision and sound transmissions be of the same order of carrier frequency as pre-war. With regard to the assignment of any new frequencies required, a conservative policy is advocated having regard to the possibility of echo trouble at higher carrier frequencies.
- (3) That the bandwidth for vision transmission be of the same order as pre-war, viz., 4 Mc/s approximately.

It is also suggested that consideration should be given to better utilisation of the above bandwidth by making use of vestigial side-band transmission and also to increasing the number of lines to that which is the optimum for the increased modulation bandwidth. The proposed figures are 525 lines (gross, interlaced); 3.25 Mc/s, maximum modulation frequency.

From the United States Radio Technical Planning Board comes the recommendation that the pre-war American television standards of 525 lines, interlaced scanning with 30 frames and a channel width of 6 Mc/s be resumed after the war.

INVASION RADIO

FULL technical details of the means whereby the B.B.C. covered the Western Front are not yet available. It is, however, known that portable miniature recording equipment, similar to that described in a recent issue of *Wireless World*, was employed by the reporters who landed with the advanced Forces.



SHELL-HOLE RADIO. A U.S. shore fire control party directing by wireless the fire of Naval guns during the Normandy landings. Note the hand-driven generator. The operator on the right is using a "handie-talkie."

Mobile recording trucks are also being used, and it is understood mobile transmitters are being set up on the shores of France.

The B.B.C. introduced on June 7th the Allied Expeditionary Forces programme, which is radiated on 285.7 metres from 5.55 a.m. to 11 p.m. The wavelength employed by this station was used prior to the war by the West of England Regional transmitter.

BIRTHDAY HONOURS

PROF. J. D. COCKCROFT, Ph.D., Chief Superintendent, Air Defence Research and Development Establishment, Ministry of Supply, is created a C.B.E. in the Birthday Honours List. **W. A. Duncan**, Deputy Director of Signals, Air Ministry, and **Dr. S. E. A. Landale**, Superintending Experimental Officer, Admiralty Signal Establishment become O.B.E.s.

Among a number of executives in the wireless industry who receive honours are: **R. H. Hacker**, managing director, Dynatron Radio; **T. H. Kinman**, head of the radio section, research laboratory, British Thomson-Houston Co.; **M. I. Lipman**, manager of one of E. K. Cole's factories; **H. L. Oura**, assistant superintendent, Designs and Development Department, Gramophone Company; **F. C. Robinson**, manager, A. C. Cossor; **W. C. Tingey**, general manager, Dispersal Factories, Dubilier Condenser Co., and **S. S. West**, development physicist, Cinema-Television, who become Members of the Order of the British Empire.

A Huey, a radio officer in the Merchant Navy, becomes an M.B.E.

Miss Grace Bristol, in charge of **McMichael Radio's** engraving plant, receives the B.E.M.

WHAT THEY SAY

RELAYING TELEVISION.—There may be some doubt whether the television industry alone can support extensive television relay chains. We must then keep in mind that such radio highways may be used for many other purposes. They may be used for a radio mail service . . . in facsimile . . . The radio chains will constitute trunk lines of telephone and telegraph communication with greater capacity than all the wire lines in existence. . . . When we once establish this radio service it will no longer be a question of cost. We will not be able to get along without it any more than we can get along without the railroads.—**Dr. E. F. W. Alexanderson**, of the *General Electric Co. of America*.

NEW PROFESSION.—I am an ionospherist. . . .—**Dr. A. L. Green**, of *Amalgamated Wireless (Australasia)*, at the I.E.E.

WORLD-WIDE NETWORK.—What is needed is a world-wide network of radio and cable communications open to all nations at uniform rates and modelled on the lines of a universal postal union. To be effective, such a system must be absolutely free from domination by any one nation or by any group of nations.—**J. L. Fly**, chairman of the *U.S. Federal Communications Commission*.

INTERNATIONAL BROADCASTING.—In the Europe of to-morrow international broadcasting should take precedence over national broadcasting.—**A. Hubert**, president of *S.A.I.T. (the Belgian wireless operating company)* to the *Radio Industries Club of Scotland*.

MORSE DIVINATION!— . . . a Waaf, who is one of a cargo of girls taken up in a trainer, is tuning in to the ground with a morse tapper.—*Inscription to picture in "Daily Herald."*

ADVICE TO B.B.C.—Never truckle to the politicians. . . . Bring the B.B.C. above all Party levels.—**Brendan Bracken**, Minister of Information.

COMMUNICATIONS

A NEW direct wireless link between this country and Uruguay was recently opened by Cable and Wireless. The service is conducted on short waves and for some hours each day a high-speed circuit is possible. The South American beam at the Dorchester station is used whilst the transmissions from the Cerrito station, operated by the Uruguayan Government, are received at Brentwood.

Direct wireless communication for Press traffic was opened between Rome and London on June 11th. An additional transmitter having been installed at Naples, the mobile wireless unit, which is operated by Cable and Wireless, has been transferred to Rome for this purpose.

NEWS FROM ABROAD

NO changes in the scheduled transmissions of news in English from oversea stations, as given in last month's issue, having been notified, the list is not included in this issue.

IN BRIEF

Wired Wireless.—Figures given in the *U.I.R. Bulletin* show that 75 per cent. of the subscribers to the Swiss wired wireless system operated by the postal authorities have a choice of five programmes. A further 21 per cent. have a choice of four programmes.

Radio in Canadian Homes.—The result of a recent census taken in Canada shows that 1,887,217 of the Dominion's 2,500,000 homes are equipped with radio.

Gallant Radio Officers.—In a statement at the ordinary general meeting of the *Marconi International Marine*

CROWNAME RADIO COMPONENTS



MILITARY demands on the electronics industry require large quantities of material made to precision standards never before approached by quantity production methods. Crowe has had signal success in solving problems of rapid production of precise electronics control mechanisms. This experienced ability will be an important factor in the post-war programmes of many firms.

★
Exclusively Represented in Great Britain by
FRANK HEAVER LTD.
Kingsley Road, Bideford, N. Devon.

CROWE NAME PLATE AND MANUFACTURING CO.
CHICAGO, ILL. U.S.A.

from **BLACK Soil**

Come lovely Flowers

And so it is that from the darkness of the present hour will emerge a brighter day when the brain and brawn of modern industry will be utilised in further peacetime products and pursuits. While serving the Government to-day we are broadening both creative and manufacturing possibilities for a happier world to-morrow. Astatic engineers are available to work in co-operation with electronic engineers in the development of new wartime equipment, especially as it may have to do with pickup and transmission of sound. Astatic crystal microphones, pickups, cartridges and recording devices will be available again for your use when those brighter days are here. Register your name with our Representative for your future benefit.

ASTATIC

THE ASTATIC CORPORATION
YOUNGSTOWN, OHIO, U.S.A.
TORONTO, CANADA.

Exclusively Represented by
Frank Heaver Ltd. Kingsley Road, Bideford, N. Devon.

World of Wireless—

Communication Company, the chairman said that since the beginning of the war to the end of last March 31 of their radio officers had received official decorations for gallantry and 72 had been officially commended for gallant conduct. In addition, 13 had been awarded the Lloyd's War Medal for bravery at sea.

World's Broadcasting Stations.—The latest figures from the Bureau of the International Telecommunications Union show that there are 2,686 broadcasting stations in the world and a further 170 under construction or contemplated. The continental distribution is: America 1,897, Europe 416, Asia 175, Australasia 155, and Africa 43.

Canada's Radio War Production.—Canada's military radio production is 33 times greater than its pre-war civilian production, whilst U.S. radio war production is 16 times greater than in peacetime. This was stated at a recent meeting of the Canadian Radio Manufacturers' Association by the President of the R.M.A. of America.

An Appeal for headphones and other wireless accessories for equipping a wireless school has been received from the commanding officer of the Bermondsey Unit of the Sea Cadet Corps. Gifts sent to the Sea Cadet Corps, Bermondsey Unit, Fair Street Schools, Tower Bridge Road, London, S.E.1, will be gratefully received.

Radio Men from N.Z.—The New Zealand Minister of Supply has announced that twelve N.Z. radio technicians and scientists are being made available to the British Ministry of Production. They will be accompanied here, in a consultative capacity, by the Controller of Radio Production.

Canadian Radio Plans.—Plans are being discussed by the Canadian House of Commons Radio Committee as to the possibility of establishing a short-wave transmitter at Vancouver, B.C. This, in conjunction with the 50-kW transmitter under construction at Sackville, N.B., will assure a complete world coverage for Canadian "psychological warfare, propaganda and goodwill."

Broadcasting Hours Curtailed.—Shortage of fuel has necessitated the curtailment of broadcasting from Radio Eireann by half an hour each evening.

Civil Promotions for Service Employees.—Cable and Wireless have informed their employees in the Armed Forces and National Defence Services that as from July 1st they will benefit from any promotions or increases of pay which would be normally due to them whilst working for the company.

Waste Paper is still needed for war purposes. Large quantities of paper have been used to equip our men on the Western Front. The paper is treated in a variety of ways according to the use to which it is to be put, some being waterproofed to make floating containers for guns and ammunition. Paper is also resin-soaked and turned into plastics.

Radio Pirates.—According to Scottish Press reports one in every forty-five users of sets in Aberdeen have paid no licence fee.

Argentina.—The power of the Argentine's new short-wave transmitter Radio-Belgrano is 135 kW. The transmitter, which is equipped with directional aerials, has a frequency coverage of from 6 to 15 Mc/s.

Institute of Physics.—Sir Frank Smith was elected President of the Institute of Physics for the year 1944-45 at the annual general meeting held on May 22nd. The following were also elected:—Vice-Presidents, Prof. J. D. Cockcroft, T. Smith and Dr. F. C. Toy; Hon. Treasurer, C. E. S. Phillips; Hon. Secretary, Prof. J. A. Crowther. All these offices take effect from October 1st next.

I.E.E. Awards.—Dr. D. Gabor, who is a contributor to our sister journal *Wireless Engineer*, has been awarded the I.E.E. Duddell Premium for his paper "Energy Conversion in Electron Valves." The Ambrose Fleming Premium is awarded to Prof. Willis Jackson, D.Sc., and Dr. L. G. H. Huxley for their joint paper "The Solution of Transmission Line Problem by use of the Circle Diagram of Impedance." For his paper on "Wave Guides in Electrical Communication" J. Kemp receives the Extra Premium. These three papers were read before the

Wireless Section during the 1943-44 Session.

Radio Industries Club.—An increase in membership from 326 to 406 during the past twelve months was recorded at the thirteenth annual general meeting of the Radio Industries Club. The membership of the Scottish Radio Industries Club is now 162.

Scottish Wireless Group.—Consideration is being given by the Scottish Centre Committee of the Institution of Electrical Engineers to the formation of a Wireless Group in Scotland.

Association of Scientific Workers.—By an agreement recently signed between the Association of Scientific Workers and the Engineering and Allied Employers' National Federation the A.Sc.W. is recognised as the body to represent scientific and technical staff of the industry. Membership of the A.Sc.W. has grown to 15,000.

Servicemen's Guild.—At a recent meeting of radio servicemen in London, it was agreed to form the Guild of Radio Service Engineers. Objects: To represent, to look after the interests of, to improve the status of, and to increase the efficiency of those engaged in this work. The annual subscription has been provisionally fixed at one guinea. An open meeting is to be held shortly. Correspondence should be addressed to J. H. Corbett, 190, Desborough Road, High Wycombe, Bucks.

PERSONALITIES

E. M. Deloraine, General Director of the Laboratories Division of the Federal Telephone and Radio Corporation, has been elected a director of the International Telephone and Telegraph Corporation. Following the last war, Mr. Deloraine was engaged on research work at the Eiffel Tower under Gen. Ferrié. In 1921 he joined the London engineering staff of the International Western Electric Company, which later became the International Standard Electric Company, and was made European Technical Director in 1933. He went to the United States in 1941. Mr. Deloraine has made many valuable contributions to the development of UHF transmission.

Pioneer Honoured.—One of the first incidents to bring wireless into the public eye—the loss of the liner *Republic* in 1909—is recalled to mind by the election of A. H. Ginman to membership of the Courts of Directors of Cable and Wireless. Mr. Ginman, General Manager of the Company in Canada and also President of the Canadian Marconi Company, was a pioneer marine wireless operator and later became manager of the coastal station of Siasconsett, Mass. From that station he handled the *Republic's* distress calls, and directed rescue operations.

Brit.I.R.E.—At a meeting of the General Council of the British Institution of Radio Engineers held recently, Leslie McMichael was unanimously nominated President-elect for the year 1944-45. He has been a Vice-President of the Institution for the past three years and was a founder member of the Radio Society of Great Britain.



ADVANCING INFANTRY keep in touch with H.Q. by means of the 7-valve "handie-talkie" which weighs about 5lb.

R.M.A. REPORT

New Representation of the Industry

THE introduction to the annual report of the Radio Manufacturers' Association records that during the past year there has been active co-operation between the Government and the industry in each of the three objectives on which the work of the Association has been based, namely:—

- (a) Direct co-operation in the war effort;
- (b) Planning for the post-war period—with relation to both home and export trade;
- (c) Maintenance of civilian reception at home at the minimum essential level.

The section of the report dealing with the provision and training of skilled personnel records that the work of the Government Wireless Personnel Committee is based on the principle that all skilled wireless personnel are regarded as a common pool from which allocations are made to the Services, the Experimental Establishments and the industry, according to the needs of each.

It is learned from the report that the Radio Industry Council has been asked by the Government to assist in the planning of the post-war employment of technicians of the following grades:—

- (a) Experienced radio engineers and scientists;
- (b) Scientific assistants of University degree or Higher National Certificate standard;
- (c) Skilled radio mechanics.

The need for maintaining the level of civilian listening has frequently been voiced by the Government. The supply of civilian receiving equipment falls under four heads:—

1. Completion of the receiving sets which were in progress in manufacturers' works when civilian production was interrupted in 1941.
2. Distribution of a number of sets imported into this country from America.
3. Production of a quantity of standardised receivers to be known as Wartime Civilian Receiving Sets.
4. Supply of components for the repair and maintenance of existing receivers.

According to the Report there are still some 70,000 sets awaiting completion. Of the American sets it is stated: "Early in 1943, the

Government decided, without consulting the British radio industry, that a considerable number of receiving sets should be imported from America."

The number of these imported sets is not expected to exceed 30,000 although the original intention of the Board of Trade was to import something like 150,000.

Standard Sets

Reference is made to the long-awaited standard receiver. Authority has been given for the production of 175,000 AC sets and 75,000 battery sets. The report states that the first of these sets, which are to be styled wartime civilian receivers, will become available about June this year and the production of the authorised 250,000 will occupy until the early part of next year.

The section of the report dealing with post-war planning refers to the necessity of remoulding the organisations in the industry, the object being the establishment of an organisation "representative of the various sections of the radio industry, and empowered by those sections to speak for the industry as a whole on matters of common interest." This resulted in the formation of the Radio Industry Council with the following terms of reference:

"To deal with matters affecting the radio industry as referred to the Council by any of the sectional organisations represented upon it; the Council to be empowered to act in any matters so referred to it.

"If the Council wishes, itself, to initiate action in regard to any matters not referred to it by one of its constituents it should only do so, either by reference back to and agreement by the constituent organisations, or by the unanimous agreement of their representatives present.

"If one or more of the bodies represented on the Council ask for the representation of a part of the industry not covered by any of the existing constituents, the Council shall be authorised to arrange such representations after due reference back to and approval by all the existing constituents."

A draft constitution has been prepared and it is proposed that the R.I.C. should, when legally constituted, take over such of the assets of the R.M.A. as may be legally transferred to it.

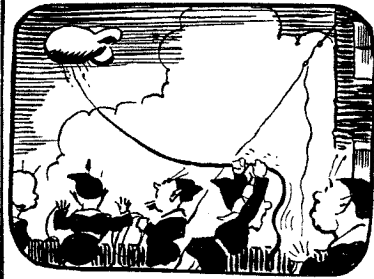

THE "FLUXITE QUINS" AT WORK.

"Something's wrong with this aerial, EE, I can't hold the blessed thing, see. Get that FLUXITE! Be slick! And let's solder it—quick! Don't leave all the tough work to me!!"

See that FLUXITE is always by you — in the house — garage — workshop — wherever speedy soldering is needed. Used for over 30 years in Government works and by leading engineers and manufacturers. Of all Ironmongers—in tins, 8d., 1/4 & 2/8.

Ask to see the FLUXITE SMALL-SPACE SOLDERING SET—compact but substantial—complete with full instructions, 7/6.

TO CYCLISTS! Your wheels will NOT keep round and true unless the spokes are tied with fine wire at the crossings AND SOLDERED. This makes a much stronger wheel. It's simple—with FLUXITE—but IMPORTANT.

The FLUXITE GUN puts FLUXITE where you want it by a simple pressure. Price 1/6, or filled, 2/6.



ALL MECHANICS WILL HAVE

FLUXITE

IT SIMPLIFIES ALL SOLDERING

Write for Book on the ART OF "SOFT" SOLDERING and for Leaflets on CASE-HARDENING STEEL and TEMPERING TOOLS with FLUXITE. Price 1d. each.

FLUXITE LTD.

(Dept. W.W.), Bermondsey Street, S.E.1

UNBIASED

Apologia

IT is, I think, a sobering thought that nobody in the world is entirely infallible, not even Mrs. Free Grid, and, as we all know, even Homer nods on occasions. I fear that I am no exception to other folk in this respect, as I must confess that I did really drop a rather heavy brick last month, the ironical part of the business being that I dropped it on my own foot. Nor have readers been slow to tell me about it, messages having come in from all sorts of places from Surbiton to Samarkand.



On my own foot.

My brick was that I framed a rhetorical question in such a manner that there was implicit in it the statement that I believed a perambulator to be a pavement vehicle rather than a road vehicle and therefore exempt from the now happily defunct ban on car radio. In actual fact, of course, a pram has no more right to be on the pavement than a steam roller.

The irony of the whole wretched business lies in the fact that I knew perfectly well that a pram was a road vehicle and not a pavement vehicle, and I stated so in no uncertain terms in the pages of this journal many years ago. The number of readers who have written to point out the fact that I was contradicting no less an authority than myself speaks volumes for the world-wide circulation enjoyed by this venerable journal. One such letter even came from a baled-out German airman who is enjoying His Majesty's hospitality in this country for the remainder of the war; he adds that he baled out of a perfectly good plane solely because of the difficulty he experienced in getting regular deliveries of *Wireless World* in the Fatherland.

The fact that I thus dropped a brick on my own foot, however, can form no excuse for the crass ignorance displayed in this matter by a

By FREE GRID

provincial bench of magistrates in a hayseed town in which lives the correspondent who sends me the details in the form of a cutting from the local paper. This bench of beaks, sitting in solemn conclave, has ruled that a pram is without doubt a road vehicle, just as though the members of the bench were themselves the originators of such a ruling. It is clearly evident that they are so ill-read that not only are they in ignorance of my own ruling on the matter but don't seem to have heard of the ruling of the High Court on this very subject in a notorious accident lawsuit of long ago. The next thing that these hirsute hicks of the rural magistracy will be doing, I anticipate, is to issue a solemn pronouncement to the effect that in their interpretation of the law murder is undoubtedly a criminal offence.

I can only add that if, as a result of my careless brick-dropping activities, I am (as indeed I am) in the Slough of Despond due to the corns and contusions on my foot, the members of this particular bench of magistrates deserve to suffer from something which is infinitely more uncomfortable, namely, "bun-yans."

Radio on the Kitchen Front

ONE does not usually expect the B.B.C. programme people to be very well versed in the deeper technical intricacies of radio, yet surely it should be the job of the engineering department to keep them well abreast of the times, technically speaking, so that they do not convict themselves of ignorance out of their own mouths and hold themselves up to the ridicule of the better-informed section of listeners who read *Wireless World*. There was a particularly glaring instance of this sort of thing recently in one of the matutinal "Kitchen Front" broadcasts in which, among other people, one of the leading lights of the B.B.C.'s announcer staff teaches our grandmothers how to suck eggs if they can manage to get hold of them.

The case in point was a lesson in cake-making and cake-baking. "Why was it," asked several

listeners in their letters, "that cakes had a nasty habit of cracking down the side while baking and emulate the Japanese rite of harikari by disembowelling themselves and making a nasty mess?" The reason, so we were told, is that the outside of a cake has a tendency to bake before the inside and to set hard. The result of this is that the half-baked contents of the inside swell out by generating steam and burst open the hard outer crust.

We were then treated to long-winded instructions about special oven temperatures and the position of the cake in the oven, the observance of which, it was claimed, would remedy this state of affairs by causing (if you were lucky) the inside of the cake to heat up before, or in any rate not later than, the outside. Such out-of-date instructions may have been all very well in Queen Victoria's days or even very much later, but surely in this age of radio heating the oven as a means of baking a cake is as dead as the dodo. The proper procedure is, of course, to apply the principles outlined in this journal, and heat the inside of the cake by means of the correct radio technique and deal with the outside later.

I may say that I have already set up an experimental cake-making plant of this nature, and am even now waiting with a copy of "*Mrs. Beeton*" in my hands, to commence operations as a preliminary to applying to the B.B.C. to go on the air in the Kitchen Front to explain my methods. At present, however, matters are held up by an unseemly wrangle with the



Take a dozen eggs.

Ministry of Food about special supplies. The fly in this particular cake lies, not in the proverbial ointment nor yet in the cake, where it might well serve as an *ersatz* current, but in Mrs. Beeton's opening sentence, "Take a dozen eggs." But I am hopeful of being able to let you have full technical details before long.

Letters to the Editor

W. W. "Quality" Amplifier With Cathode Follower • Output Load

"Cathode Follower Output Stage"

THE article by C. J. Mitchell in your April issue interested me greatly; since reading it I have modified an amplifier, identical in the last two stages with the *Wireless World* Quality Amplifier, to take advantage of this type of coupling. The alterations and resulting performance may be of interest to readers.

of the circuit and ensures a high damping factor—approx. 20. It should be mentioned that, to benefit to the maximum possible extent from the electrical damping, the magnetic flux in the speaker should be as large as possible.

It is difficult to assess the improvement in performance because, at a standard approaching—if not actually reaching—per-

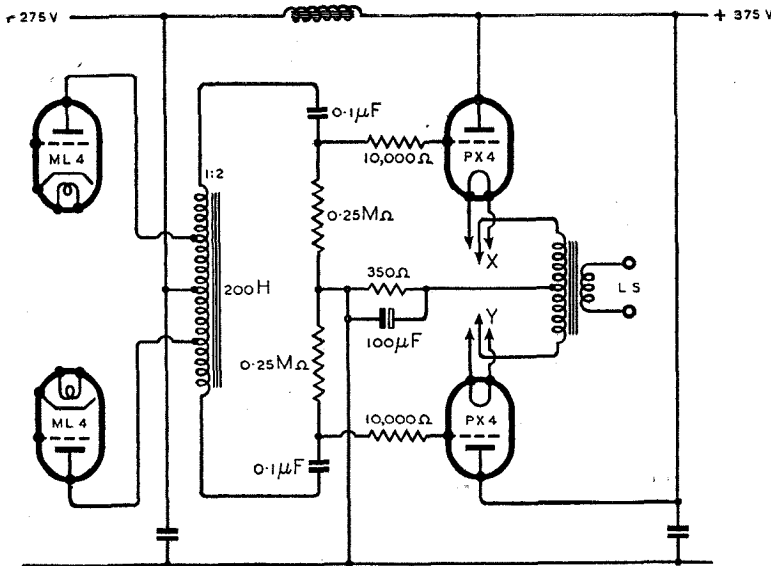

Diagram showing modifications to Quality Amplifier.

First, considering alterations, the chief problem lies in supplying the output stage with about 350V peak input. The circuit shown has been used to replace the original MHL4 voltage amplifying stage, and is a combination of auto-transformer and choke coupling. The overall inductance of the winding at 230V AC and without DC excitation is 250 henrys. This stage has a gain tending to 24, and will handle 15 volts input so that an output of 360V peak is available. An input of 8 volts is needed to the phase splitter, which is of the resistance-capacity type.

Common bias is used for the PX4's, as this keeps the resistance out of the signal-carrying section

fection, a psychological factor enters into the appreciation which is out of all proportion to the physical change; as a result, I feel I can do no more than point out in what respects performance is impressive without in any way implying how much more so.

Your correspondent, D. Baker (May issue) has referred to a sense of unlimited power. I agree that this impression is created, but there is something in addition, probably resulting from the high electrical damping, which greatly reduces spurious speaker effects, such as combination tones and cross-modulation. The result is a great increase in reality in the high audio frequencies.

Bass response is probably the

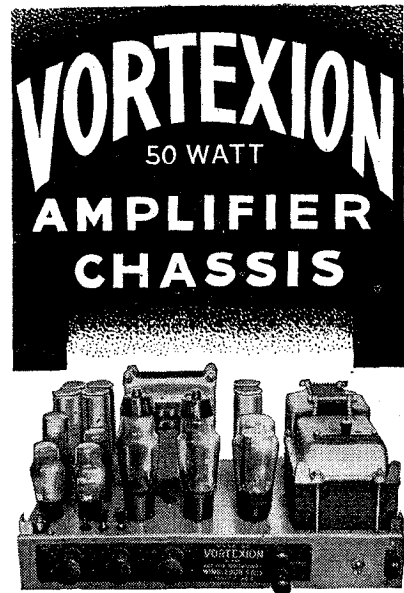

The new Vortexion 50 watt amplifier is the result of over seven years' development with valves of the 6L6 type. Every part of the circuit has been carefully developed, with the result that 50 watts is obtained after the output transformer at approximately 4% total distortion. Some idea of the efficiency of the output valves can be obtained from the fact that they draw only 60 ma. per pair no load, and 160 ma. full load anode current. Separate rectifiers are employed for anode and screen and a Westinghouse for bias.

The response curve is straight from 200 to 15,000 cycles in the standard model. The low frequency response has been purposely reduced to save damage to the speakers with which it may be used, due to excessive movement of the speech coil.

A tone control is fitted, and the large eight-section output transformer is available to match, 15-60-125-250 ohms. These output lines can be matched using all sections of windings, and will deliver the full response to the loud speakers with extremely low overall harmonic distortion.

PRICE (with 807, etc. type valves) **£18.10.0**

Plus 25% War Increase

MANY HUNDREDS ALREADY IN USE

Supplied only against Government Contracts

VORTEXION LTD.
257, THE BROADWAY,
 WIMBLEDON, S. W. 19.
 Phone: LIBerty 2814

Letters to the Editor—

second most outstanding quality and plucked bass string sound uncannily real.

To sum up, I would say that there is an all-round sense of realism which is entirely new to me and which I cannot explain. The loss in sensitivity through modifying the Quality Amplifier may make immediate change impossible for some owners, but is certainly worth considering. Lastly, the speaker must be a good one for first-rate results. The effects of low output impedance are lost with a speaker of low efficiency. A. C. ROBB.

Liverpool.

“Optimum Load”

I WAS much interested in the article on “Optimum Load” by Dr. K. R. Sturley which appeared in the May issue. As Dr. Sturley rightly states, considerable mental confusion exists as to the reason why maximum power output is obtained from a triode when the load resistance R in the anode circuit is equal to twice the anode AC resistance r_a . His article should be of help in removing this confusion, and your readers may be interested in the following alternative explanation, which also gives the correct value of grid bias to be used and which I have found acceptable to students.

The diagram shows three

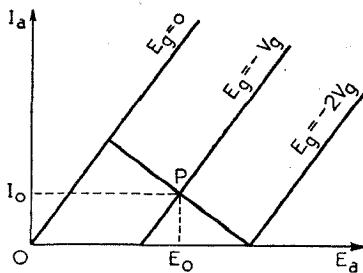

idealised static characteristic curves and the desired load line and operating point P. The anode voltage E_0 is known and is fixed.

The general equation for the static characteristic curves is given

$$\text{by } I_a = \frac{E_a + \mu E_g}{r_a}$$

At the operating point P:

$$I_0 = \frac{E_0 - \mu V_g}{r_a} \dots (1)$$

I_0 is also the peak value of the alternating component of I_a and V_g is the peak value of signal applied to grid as well as the desired grid bias.

$$\text{Hence } I_0 = \frac{\mu V_g}{r_a + R} \dots (2)$$

From equations (1) and (2) we

$$\text{obtain: } V_g = \frac{E_0}{\mu} \times \frac{r_a + R}{2r_a + R} \dots (3)$$

Substituting for V_g in equation (2)

$$\text{gives: } I_0 = \frac{E_0}{2r_a + R}$$

AC power delivered to load, P,

$$= \frac{I_0^2}{2} \times R = \frac{E_0^2 R}{2(2r_a + R)^2} \dots (4)$$

For maximum power output

$$\frac{dP}{dR} = 0, \text{ or } R = 2r_a.$$

Substituting in equations (3) and (4) gives respectively:—

$$\text{Correct grid bias} = \frac{3}{4} \cdot \frac{E_0}{\mu}$$

$$\text{Maximum power} = \frac{E_0^2}{16r_a}$$

W. H. DATE.

The Polytechnic,
London, W.

Variable- μ or Variable- μ ?

I AM sorry that the great guns of your Editorial, hitherto directed with such good effect against the grosser monstrosities of wireless jargon, scored such a lamentable miss in your June issue. To change the metaphor a little, you should have used both barrels on “variable- μ and variable- μ ”; instead, you let both these miserable specimens get away unscathed.

Every amplifying valve has both variable- μ and variable- μ characteristics, since the I_a/E_g curves always alter their slope and spacing as they approach the zero anode current base line. It is only convention that associates one particular type of curvature with the term “variable- μ ,” which by itself tells you nothing unless you are in the know—a perfect example of jargon.

Until we find the ideal term conveying the conception of gradual rate of change of curvature or minimum cross-modulation when heavily biased, let us make do with “remote cut-off,”

“sharp cut-off,” or “long base,” “short base,” which tell at least part of the story.

H. MORGAN.

London, S.E.

Filament Temperature Effects

I READ with interest “Random Radiations,” by “Diallist,” in your issue of May, 1944, respecting the hot and cold resistance of electric lamp filaments. About 1926 I utilised the slow rise in resistance to effect the release of a relay 10 seconds after energisation. A 40W metal filament vacuum lamp was used, and the relay and lamp in series were operated through controlling contacts at 3 to 4 volts. This “10 seconds” operation has been utilised for a particular application is signalling on the London, Midland and Scottish Railway.

F. BURTON,

Elec. Asst. to Divl. Signal and Tele. Engr., L.M.S. Rly. Crewe.

SURELY failure of lamp filaments is caused by the combined effects of slow combustion, erosion and movement during the frequent periods when the temperature is changing. Whilst it is readily agreed, but not important, that the movement of electrons is at its maximum limit when the filament is cold, due to its low internal resistance, the temperature gradient rises only sufficiently eventually to reach the normal working temperature of the lamp which is a function of the applied EMF.

Quite irrespective of the actual movement of electrons in quantities, no matter how multitudinous, but not of their effects in terms of heat, the lamp whilst energised passes unobtrusively away without noticeable loss of illumination by a popular means of its own selection. The disintegrating filament eventually burns away, usually from one of the electrodes, and an arc is formed which bridges the gap. The vacuum assists the arc and also delays rapid burning of the disjoined members, and the lamp as an integral piece of equipment has died; but its effect continues to live—until it is switched off. Reapplication of potential required to give normal illumina-

tion is not capable of breaking down the dielectric between the component parts of the circuit that have previously become dis-united.

Consequent upon the fact that this frequent phenomenon may not have been closely observed, "Diallist," in conjunction with the man in the street, formulates the erroneous belief that the lamp was not defective when it was switched off.

REGINALD A. BANKS.

Kew Gardens, Surrey.

I SHOULD like to take your contributor "Diallist" gently to task for using such a vague expression as "excessive load" in connection with failure of a lamp just switched on. It is presumably not a temperature effect since the whole thing is due to the fact that the temperature has not risen.

Would he say that it is mainly characteristic of gas-filled lamps and not straight filament vacuum types? If so, is it due to sudden violent attraction between turns of the spiral brought about by excessive current (a well-known electromagnetic effect)? This would account for breaks by tension if the filament becomes brittle by age and use. Sometimes, too, the fuse is blown and the inside of the lamp wrecked when the lamp fails on switching on. It seems that here the attraction may have caused a loop of filament to be short-circuited out, the further increased current causing more loops to short circuit to give the resulting minor disaster.

S. E.

"PENTODE-DIODE VALVE
VOLTMETER"

A Correction

In this article, which appeared in our June issue, the value of R16 is given on p. 163 as 24,030 ohms. This should be 2,430 ohms.

GOODS FOR EXPORT

The fact that goods made of raw materials in short supply owing to war conditions are advertised in this journal should not be taken as an indication that they are necessarily available for export.

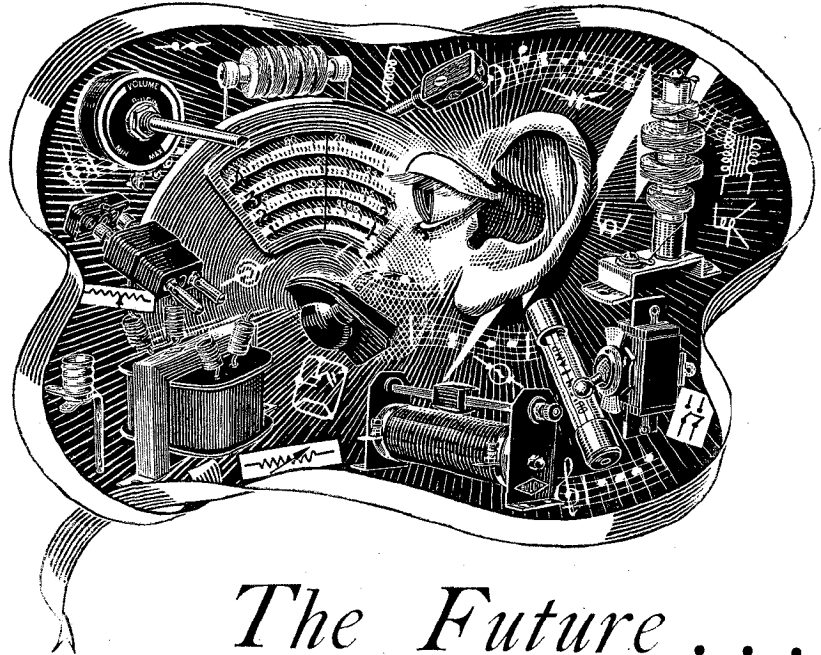

The Future . . .

ALTHOUGH concealed today in tropical kit or battledress, without its familiar trademark, discerning technicians can easily recognise the well-known brand of BULGIN RADIO PRODUCTS in every piece of Service radio apparatus. Today, as in the past, they stand predominant for originality, design and reliability, ready to co-operate in the future, in the shape of "things to come."

(Please quote priority and Contract Nos.)

"The Choice of Critics"



Registered Trade Mark

A. F. BULGIN & CO. LTD., BYE PASS RD., BARKING, ESSEX
Radio and Electrical Component Manufacturers.

TEL. : RIPPLEWAY 3474 (5 lines).

RECENT INVENTIONS

BROADCASTING AERIALS

A SHORT-WAVE frame aerial with a substantially circular radiation characteristic consists of eight right-angled elements $E_1 \dots E_8$, arranged symmetrically as shown about a common centre. The four outer corners of the square so made are coupled together by condensers C , so that the periphery forms a "closed" loop.

The aerial is energised through the four segments S at the common centre, which may be made as a hollow hub and threaded over the supporting mast M . Separate insulation is unnecessary since each of the segments is at a voltage node.

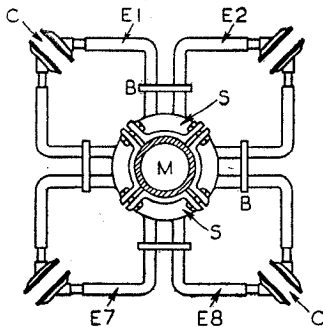

Aerial for circular radiation.

Correct matching is ensured by adjusting the position of the shorting bars B , which in effect varies the overall length of the corresponding feed line.

Standard Telephones and Cables, Ltd. (assignees of R. S. Hampshire). Convention date (U.S.A.) July 12th, 1941. No. 558473.

CATHODE-RAY TUBES

DURING the processes of scanning, the electron stream is apt to develop negative charges on the inner or impact surface of the fluorescent screen. These tend to retard the speed of the oncoming electrons, and so produce the effect known in television as interline flicker or flutter. For this reason it has already been proposed to cover the back surface of the screen with a metallic layer, but the picture must then be viewed from the side of the screen against which the scanning beam strikes.

The remedy now suggested is to cover the inner surface of the fluorescent screen with a metallic layer, which is made sufficiently thin to allow the scanning electrons to pass through, without any appreciable loss of velocity. The picture can then be viewed in the usual way, *i.e.*, from the front of the glass bulb. The metallic layer is preferably made of aluminium, of a thickness not exceeding 5 microns, and is coated with fluorescent material on the side next to the glass bulb of the tube.

Cinema-Television, Ltd. (communicated by C. S. Szegho). Application date September 14th, 1942. No. 559316.

A Selection of the More Interesting Radio Developments

TUNING-IN FM SIGNALS

THE flat response of a receiver for frequency-modulated signals does not favour the use of the ordinary type of tuning indicator.

According to the invention an audible tuning note, say of 150 c/s, is injected into the set from a local source as an amplitude modulation on the suppressor grid of the usual limiter valve, and is passed through the discriminator valve to a branch output containing the tuning indicator, which can then conveniently take the form of a pair of headphones.

The audible note may be switched in during the period of tuning only, or it may be left permanently in circuit; in the latter case it will give an audible warning of any frequency "drift" either in the transmitter or receiver. If the receiver is of the type that is operated from a low-voltage supply through a vibrator and a step-up transformer, the tuning note can be taken from the unsmoothed side of the HT filter.

The amplitude of the injected note falls to zero when the set is brought accurately into tune, but rises in strength on both sides of the critical point.

The Mullard Radio Valve Co., Ltd., C. E. G. Bailey and G. I. A. Bywaters. Application date June 30th, 1942. No. 558467.

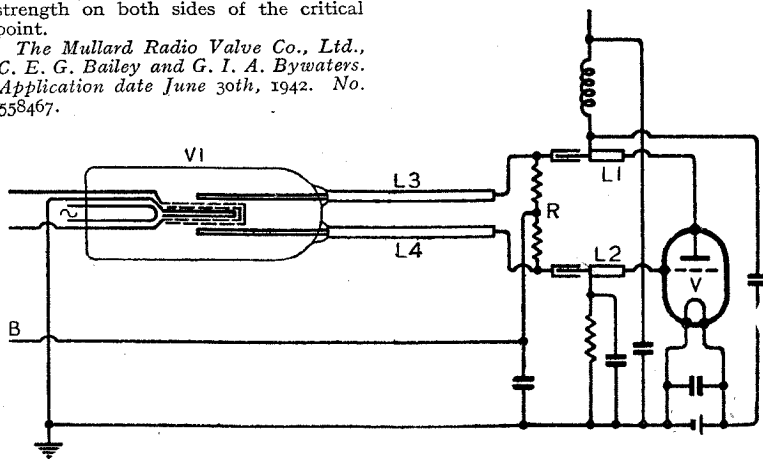

Constant frequency short wave oscillator.

FM RECEIVER

THE undesired amplitude variations which intrude themselves into the energy content of a frequency-modulated signal are usually removed before detection by means of a limiter valve which, to be effective, must be overdriven, *i.e.*, loaded to saturation. This in turn requires a high level of amplification to be applied to the incoming carrier wave.

It is now proposed to omit the limiter stage and to couple the last IF amplifier directly to the usual pair of frequency-discriminating diodes, the load resistance of the latter being connected to the two grids of a pair of

push-pull amplifiers. Since the phases of the voltages set up by the FM signal across the two diodes are of opposite polarity, they will combine additively in the push-pull output. On the other hand, any unwanted amplitude variations that may be present will generate voltages of like polarity across the diodes. By suitably selecting the circuit constants, these voltages can also be made equal in value, so that they will automatically cancel out.

Marconi's Wireless Telegraph Co., Ltd. (assignees of H. O. Petersen). Convention date (U.S.A.) November 27th, 1941. No. 559290.

FREQUENCY CONTROL

THE frequency of a short-wave oscillator V is made to vary with a control voltage applied to the grid of an auxiliary valve V_1 . The arrangement can be used to neutralise the effect of temperature changes and for automatic frequency control generally.

A tuned feed-back circuit between the anode and grid of the oscillator includes a pair of Lecher wires L_1, L_3 and L_2, L_4 respectively. These terminate inside the valve V_2 , where they form a pair of anodes and are subject to the space charge developed by the screen grid of that valve. The distributed capacity along the Lecher wires, and therefore their effective electrical length, will thus vary with the voltage applied to the control grid of the valve V_2 , and with it the operating frequency of the oscillator V . A

negative bias, applied from a source B through a resistance R , prevents the wires L_3, L_4 from taking current during any part of the high-frequency cycle.

Standard Telephones and Cables, Ltd., and C. N. Smyth. Application date February 20th, 1940. No. 558454.

The British abstracts published here are prepared with the permission of the Controller of H.M. Stationery Office, from specifications obtainable at the Patent Office, 25, Southampton Buildings, London, W.C.2, price 1/- each.